

***ACPO Code of
Practice for
Operational
Use of Road
Policing
Enforcement
Technology***



Code of practice for operational use of enforcement equipment

Title: ACPO Code of Practice for Operational use of Enforcement Equipment

Owner: ACPO Road Policing Business Area

Author: ACPO Road Policing Enforcement Technology Committee

Implemented: 1 November 2002

Review: 31 December 2004

Version: 2.1 (1 March 2003)

Amendments:

Page 40 Section 7	Amended Cross References
Page 72 Section 15	Amended Cross References
Page 62 Section 13	Paragraph wording clarified
Page 86 Appendix A	Leica XV2 Speed Laser test results
Page 92 Appendix B	New Devices inserted



Foreword

The Road Traffic Offenders Act 1988 required the Home Office Type Approval of evidential radar speed meters. The Road Traffic Act 1991 expanded this provision to allow for the type approval of other devices used in the enforcement of road traffic law.

While Type Approval provides an assurance of the technical accuracy and reliability of a device, devices do need to be properly used. Reliance on instructions from manufacturers alone is insufficient to protect evidential integrity and therefore the Police, in consultation with the Home Office Police Scientific Development Branch (PSDB), have laid down operational standards.

The devices referred to in this Code of Practice, although the subject of rigorous field and laboratory testing, are only as reliable as the user. It is imperative that the procedures set out in this Manual are applied scrupulously - each link in the evidential chain is of importance, and upon its careful application lays the integrity of the Police Service.

These standards are in your hands.

R Brunstrom
Chief Constable
North Wales Police
Head of ACPO Road Policing Business Area



Code of practice for operational use of enforcement equipment



Introduction

This Association of Chief Police Officers' (ACPO) Code of Practice provides the operational standards for the Police Service use of road policing enforcement equipment. It should be read in conjunction with manufacturers' instructions. The Code of Practice takes precedence where ACPO's standards vary from those laid down by the manufacturers.

Forces should also have regard to the Home Office circulars, which have been and will be issued on the installation, use and procedures relating to technology for road policing. Circulars on the same subject have been and will be issued to highway authorities and magistrates courts. Another source of guidance is the handbook periodically reviewed and released by the project board responsible for the national rollout of casualty reduction partnerships funded through 'netting off'.

This Code of Practice is for the guidance of the enforcer and for the information of those accused of alleged offences who wish to satisfy themselves the correct procedures have been followed when technology was used to detect the alleged offence. While ACPO claim copyright of this Code of Practice this does not prevent the supply of copies or extracts to interested parties. The Code is on the ACPO web site to which the public have access.

The Road Policing Enforcement Technology Secretary has provided each police force with a CD-ROM of the manual, which is certified as a true copy of the original document. This allows the production of a true copy for reference at court.

A list of all Type Approved devices supplied by the Home Office is attached as Appendix B.



Code of practice for operational use of enforcement equipment



Contents

FOREWORD	1
INTRODUCTION	5
CONTENTS	7
HUMAN RIGHTS STATEMENT	11
OVERVIEW	11
KEY RIGHTS AND LEGITIMATE AIMS.	11
ACPO ROAD POLICING ENFORCEMENT TECHNOLOGY COMMITTEE	13
ROAD POLICING ENFORCEMENT TECHNOLOGY TERMS OF REFERENCE	15
1.HOME OFFICE TYPE APPROVAL	17
1.1 WHAT IS HOME OFFICE TYPE APPROVAL?	17
1.2 HOW IS THE TYPE APPROVAL MADE KNOWN?	17
1.3 WHAT IS THE TYPE APPROVAL PROCESS?	17
1.4 DOES ROAD POLICING ENFORCEMENT TECHNOLOGY ACT AS A 'CONSULTANCY'?	19
1.5 WHAT IS THE ADVANTAGE OF HOME OFFICE TYPE APPROVAL?	19
1.6 WHAT COULD INVALIDATE TYPE APPROVAL?	20
1.7 CAN TYPE APPROVED DEVICES BE ALTERED AT ALL?	20
1.8 WHO IS RESPONSIBLE FOR MAINTAINING THE TYPE APPROVAL STANDARDS?	21
1.9 DOES PROXIMITY TO THE START OR THE END OF A SPEED LIMIT ON A PARTICULAR SECTION OF ROAD HAVE ANY OPERATIONAL SIGNIFICANCE?	21
GLOSSARY OF TYPE APPROVAL TERMS	23
2.AIRWAVE (TETRA) RADIO AND ENFORCEMENT EQUIPMENT.	25
2.1 THIRD PARTY INTERFERENCE	25
3.POLICE (HEALTH AND SAFETY) ACT 1997	27
4.OPERATIONAL TRAINING	29
4.1 OBJECTIVES FOR TRAINING ENFORCEMENT DEVICE OPERATORS	29
4.2 ADDITIONAL TRAINING OBJECTIVES FOR TIME/DISTANCE DEVICES	29
5.ATTENDED ACTIVELY OPERATED DEVICES: PRESENTATION OF EVIDENCE	31
6.SPEED DETECTION USING A SPEEDOMETER FITTED TO A PATROL VEHICLE	33
6.1 MEANS OF CHECK	33
6.2 MINIMUM DISTANCE	33
6.3 SPEEDOMETER ACCURACY	33
6.4 MEASURED DISTANCE	33
7.RADAR	35
7.1 THE DOPPLER PRINCIPLE	35
7.2 RADAR COVERAGE	37



Code of practice for operational use of enforcement equipment

7.3	COSINE FACTOR	38
7.4	SITE SELECTION	38
7.5	SUMMARY	39
7.6	RADIO INTERFERENCE	39
7.7	RADIATION HAZARD	40
7.8	CARE AND MAINTENANCE	41
7.9	ANNUAL CALIBRATION	41
8.	PARABOLIC RADAR	43
9.	OPERATING HAND-HELD RADAR	45
9.1	HEALTH AND SAFETY	45
9.2	DISTANCE AWARENESS	46
9.3	DISTANCES TO STOP (SOURCE HIGHWAY CODE)	46
9.4	MULTIPLE VEHICLES	47
10.	OPERATING ROADSIDE RADAR	49
10.1	CHOICE OF SITE - HEALTH AND SAFETY:	49
10.2	SETTING UP THE RADAR METER AND OPERATION	51
11.	TIME/DISTANCE TYPE DEVICES	53
11.1	HOME OFFICE TYPE APPROVAL	53
11.2	BASIC PRINCIPLES	53
11.3	TYPES OF CHECK	54
11.4	CALIBRATION	56
11.5	RADIO INTERFERENCE	57
11.6	UNATTENDED AUTOMATIC TIME DISTANCE DEVICES	57
12.	CHRONOMETERS	59
12.1	RADIO INTERFERENCE	59
13.	SENSOR OPERATED ROADSIDE SPEEDMETERS	61
13.1	INTRODUCTION	61
13.2	SITE SELECTION AND SAFETY	61
13.3	CHECKING PROCEDURES PRIOR TO USE	62
13.4	SENSOR INSTALLATION ON SITE	62
13.5	RADIO INTERFERENCE	62
14.	LASER/OPTICAL SPEEDMETERS	65
14.1	INTRODUCTION	65
14.2	HAND-HELD	65
14.3	RANGE	66
14.4	COSINE/ANGULAR EFFECT	66
14.5	EYE SAFETY	67
14.6	CARE AND MAINTENANCE	67



14.7 CALIBRATION/TESTING	68
14.8 RADIO INTERFERENCE	68
15. CAMERAS IN, OR ATTACHED TO, ENFORCEMENT DEVICES	71
15.1 INTRODUCTION	71
15.2 CRITERIA FOR SAFETY CAMERA SITE SELECTION	71
15.3 ATTENDED ACTIVELY OPERATED DEVICES	72
15.4 UNATTENDED/AUTOMATIC DEVICES	72
15.5 CRIME PREVENTION	73
15.6 TRAILER MOUNTED UNATTENDED/AUTOMATIC DEVICES	74
15.7 HANDLING OF FILM AND VIDEO TAPE	75
15.8 FILM PROCESSING	75
16. SAFETY CAMERA ENFORCEMENT, OFFICE PROCEDURES	77
16.1 THE SECONDARY CHECK	78
16.2 THE USE OF FRONT PHOTOGRAPHY IN ROAD POLICING ENFORCEMENT	78
16.3 THE PROTOCOL	79
16.4 GUIDANCE ON 'EMERGENCY VEHICLES' DETECTED BY AUTOMATIC OR ATTENDED ENFORCEMENT CAMERAS.	80
16.5 IMMEDIATE OR EMERGENCY RESPONSE CALLS.	81
16.6 STORAGE OF INFORMATION	82
16.7 PROSECUTION PROCEDURES AND ADVICE ON GOOD PRACTICE	82
16.8 CASES ADJOURNED SINE DIE DUE TO NO DATE OF BIRTH	83
APPENDIX A	86
DIGITAL RADIO AND TRAFFIC ENFORCEMENT EQUIPMENT	86
APPENDIX B	92
SPEEDMETERS TYPE APPROVED BY THE SECRETARY OF STATE FOR POLICE USE	92



Code of practice for operational use of enforcement equipment



Human Rights Statement

Overview

Consideration has been given to the compatibility of this policy and related procedures with the Human Rights Act; with particular reference to the legal basis of its precepts; the legitimacy of its aims; the justification and proportionality of the actions intended by it; that it is the least intrusive and damaging option necessary to achieve the aims; and that it defines the need to document the relevant decision making processes and outcomes of action.

In the application of this Code of Practice, the police service will not discriminate against any persons regardless of sex, race, colour, language, religion, political, or other opinion, national or social origin, association with national minority, property, birth or other status as defined under Article 14, European Convention Human Rights (ECHR).

Practitioners should ensure that the recording of significant decision-making processes establishes that such interventions are proportionate in the particular circumstances of the case and are based upon reasonable and objective grounds that minimise the likelihood of inadvertently discriminatory practice.

Members of the public may make complaints about the application of this Code verbally or in writing via the police complaints procedure. If the matter of complaint concerns the collection and/or use of personal information, a complaint to the Information Commissioner may also be appropriate. If complaints or concerns arise about the Code of Practice itself, then these should be brought to the attention of the ACPO Road Policing Enforcement Technology Secretariat (contact details are available from the ACPO Internet Website).

Key Rights and Legitimate Aims.

Ultimately, the enforcement of relevant offences may be through the courts. It follows that formal prosecutions launched as a result of the application of this Code of Practice may interact with defendants' Article 6 (Fair Trial) rights. Adherence to the recommendations within this Code of Practice and to disclosure legislation should ensure that any engagement with this right is securely lawful.

Article 8 (Privacy) rights also have the potential to be engaged by the application of this Code. For example, images of vehicles capable of being used to identify drivers may interact with the privacy rights of the prospective defendant and any other occupants of the vehicle.

In addition, the Police Service's positive obligations towards Article 8 rights



Code of practice for operational use of enforcement equipment

impose a duty to take reasonable steps to ensure that the physical integrity of the public and colleagues is maintained. This emphasises the need to ensure that regular Health and Safety risk assessments are carried out and that appropriate training and equipment is provided to staff installing or using enforcement equipment.

Interactions with 'qualified' rights like Article 8 must have a basis in law, be proportionate and pursue a 'legitimate aim'. This Code of Practice recognises the need to take steps to ensure the health and safety of staff and the public as well as the pressing need to reduce road collisions and casualties. As a result the purposes of the Code securely pursue the following legitimate aims: the interests of public safety, the prevention of crime [and disorder] and the protection of the rights and freedoms of others.

In the event of equipment malfunction or other circumstances whereby the detection of an offence maybe unsound, officers are prohibited from making detections or pursuing prosecutions.

It should also be noted that legislation protects drivers of emergency vehicles from prosecution dependent upon the use to which the vehicle is being put at the time.



ACPO Road Policing Enforcement Technology Committee

The Association of Chief Police Officers Road Policing Enforcement Technology Committee is chaired by the ACPO Road Policing Technology portfolio holder supported by a Secretariat and delegates drawn from:

- Senior Road Policing Officers (one delegate from each ACPO region reporting back to the Senior Traffic Officers Conference)
- Home Office
- Home Office Police Scientific Development Branch
- Department for Transport Police Liaison Officer
- ACPO/Highways Agency Liaison Officer

Other persons temporarily co-opted onto the committee to provide technical, legal or operational expertise.

The committee meets regularly to progress all issues arising from the terms of reference shown below. In between meetings the Chair, Secretariat and delegates will continue to progress issues relating to devices undergoing type approval and provide a liaison between the operational officer, manufacturers, government agencies and ACPO.

Ideally the first point of contact for any query relating to road policing enforcement equipment should be the Road Policing Enforcement Technology Secretariat. Contact details are on the ACPO website.



Code of practice for operational use of enforcement equipment



Road Policing Enforcement Technology Terms of Reference

To examine, review and make recommendations on technical aids for road policing enforcement technology.

To consider and report on any road policing enforcement technology matter referred to the Committee by ACPO.

The terms of reference allow Road Policing Enforcement Technology to examine and introduce new technology for casualty reduction while at the same time examining and approving variants of existing technology thus increasing the market choice for police forces and casualty reduction partnerships.



Code of practice for operational use of enforcement equipment



1. Home Office Type Approval

1.1 What is Home Office Type Approval?

The purpose is to ensure devices are accurate, reliable and robust and provide accurate evidence leading to safe convictions. Home Office Type Approval is granted for enforcement devices that have been manufactured or supplied to the strict criteria laid down in handbooks produced by Home Office Police Scientific Development Branch (PSDB) and are intended for police use. If the device meets the criteria and is successful in Type Approval testing the supplier and the Home Office enter into a Type Approval agreement. This places a strict contractual obligation on the supplier to ensure all devices supplied for road policing enforcement in England, Northern Ireland, Scotland and Wales comply exactly with the devices tested.

1.2 How is the Type Approval made known?

The Home Office will ensure a copy of all Type Approval Orders is sent to every police force in order to ensure a copy can be produced at court when required. Any person or organisation can obtain a copy of a statutory instrument from The Stationery Office, or orders issued from January 1998 onwards can be downloaded from www.homeoffice.gov.uk.

1.3 What is the Type Approval Process?

The process for acquiring Home Office Type Approval has two parts: an ACPO Road Policing Enforcement Technology part followed by a Home Office part.

Part 1. ACPO ROAD POLICING ENFORCEMENT TECHNOLOGY

Introduction of a new device – The company contacts the Secretary of Road Policing Enforcement Technology.

The equipment is viewed by the Secretary and PSDB. If the Secretary feels it has merit, PSDB requests a technical description and Health and Safety information.

PSDB advise the Secretary when an adequate technical description has been obtained and whether the device is safe to demonstrate to Road Policing Enforcement Technology.

The Secretary decides whether to invite the company to demonstrate the device to Road Policing Enforcement Technology.

The company presents the device to Road Policing Enforcement Technology and the committee decides whether to continue with the process. If so, it allocates three forces (or two for a fixed installation) to conduct the tests.



Code of practice for operational use of enforcement equipment

The Secretary advises the company of the committee's decision and sends the company a copy of a document outlining the Type Approval process together with a copy of the document entitled Statement of Intent. This sets out the obligations of the company, Secretariat and PSDB during the type approval process. A signed copy must be returned by the company.

The company also has to contact PSDB and provide all technical documentation, Health and Safety information, and statement of modes of use to be tested as required by PSDB.

When PSDB have received adequate documentation it will inform the Secretary and provide advice to police forces on any particular aspects to test.

The selected forces conduct operational tests in accordance with Road Policing Enforcement Technology guidance and send the Secretary a test report when completed.

The Secretary circulates the test reports for consideration at the next Road Policing Enforcement Technology meeting.

Road Policing Enforcement Technology considers all the reports and decides whether the police service would like Home Office to proceed with Type Approval.

The meeting minutes will provide a record of this decision and the Secretary will write to PSDB to formally advise them of the decision.

Part 2. HOME OFFICE

PSDB obtains full technical documentation including software sources, PROMS, circuit diagrams layouts and parts lists.

The company submits the equipment tested to one of the Home Office approved test houses for technical testing against the requirements specified in PSDB handbooks.

A copy of the test house report is submitted to PSDB. When PSDB are content all necessary tests have been satisfactorily completed they recommend Type Approval to the Home Office.

The Home Office prepare a formal agreement with the company, which requires them not to modify the equipment without prior Home Office agreement.

The Home Office prepare the necessary legal documentation and submit the Approval for Minister's signature.



Code of practice for operational use of enforcement equipment

The Home Office inform forces of the Type Approval.

The police service does not normally charge for operational testing. Road Policing Enforcement Technology recognises the tremendous burden this can place on a force and for this reason the Secretariat will not facilitate the start of operational testing until PSDB confirms it has received all of the required technical data. It is expected all equipment entering the type approval process has completed its development and is ready to test. The Secretary and PSDB may require companies to demonstrate their equipment is ready and fit to test. Road Policing Enforcement Technology also reserves the right to charge suppliers (at private hire of police officer rates) where testing has to be repeated as the result of errors made by the supplier.

All reports generated by either the police service or PSDB are, 'commercial in confidence'. The police reports remain the property of ACPO. PSDB retain all supplied technical information even where a device fails or is withdrawn from Type Approval. The police service never has access to the technical data supplied by the commercial concern.

1.4 Does Road Policing Enforcement Technology act as a 'consultancy'?

The strict answer is no but in the real world one must accept that suppliers may glean some guidance from the discussions around their demonstrations. However Road Policing Enforcement Technology works within 'commercial in confidence'. This means no member may openly discuss any aspect of any device or component (including software) not already placed in the public domain by the commercial concern.

Thus Road Policing Enforcement Technology cannot, and will not, advise a commercial concern in respect of research and development issues. Road Policing Enforcement Technology will comment on the operational acceptability of devices under demonstration or test but market research and product placement are wholly issues for the commercial concern.

The adherence to 'commercial in confidence' also means Road Policing Enforcement Technology members cannot advise any person or organisation of devices which are, or have been, within the type approval process.

1.5 What is the advantage of Home Office Type Approval?

Section 20 of RTOA 1988 states, 'On the prosecution for any person for any speeding offence, evidence of the measurement of any speed by a device designed or adapted for measuring by radar the speed of motor vehicles shall not be admissible unless the device is of a type approved by the Secretary of State'. This provision applies to radar but amendments have been made to the legislation to allow for laser and digital systems. The approval process



Code of practice for operational use of enforcement equipment

gives the public and the courts reassurance measurements from a particular device can be relied upon as evidence.

In fact some devices, such as Vascar, Police Pilot and Provida 2000 do not have Home Office Type Approval. Instead, these time/distance devices are ACPO approved. The main reason for this is their extreme level of operator interaction and attention during operation. The devices do not calculate the speed of the vehicle in its entirety. The police officer has to enter the time and distance travelled and is often in a position to correlate the derived speed with that shown on the police vehicle speedometer. With these devices, the more likely legal challenge is to the accuracy of the operator rather than that of the device.

However where a device is neither Type Approved or ACPO approved the operator will have to be able to prove how the device worked, that it was working correctly at the time and was not affected by any external influence. In practice they would have to bring expert evidence to court every time and the court may still determine it will not accept the evidence adduced by the device. The defendant will be acquitted and costs will either have to be met by the Police or from central funds.

1.6 What could invalidate Type Approval?

Any change or addition to the device, the software, any enclosure constructed to house the device during operational use, any unapproved power source, the method of secondary check and the operator's manual. This means devices can only be used with agreed power sources, enclosures, software and approved leads or connections. They can only be used within the enclosures approved for that specific device. Nothing should be placed in an enclosure that is not included within Type Approval when the device is being used for enforcement purposes.

1.7 Can Type Approved devices be altered at all?

Yes but only after strict agreement with the Home Office PSDB and The Home Office. At any time the supplier may apply to PSDB to make additions or amendments to the device, its software or any other component parts, or to the operator's manual. The supplier cannot make the change without prior written agreement. Some minor changes may be agreed on the supply of technical specifications and explanations to PSDB but other changes may require full Type Approval testing. PSDB will specify the tests required.

The supplier has the responsibility of advising the customer once agreed amendments can be made. When necessary devices will be recalled for modification but, if possible, modifications will be made during the annual calibration.



1.8 Who is responsible for maintaining the Type Approval standards?

The Home Office, ACPO Road Policing Enforcement Technology, the equipment supplier and the operator share responsibility for ensuring devices remain within the specification agreed for the Type Approval. For the Home Office, Road Policing Enforcement Technology and the operator it is a matter of the integrity of the process; for the supplier it is a contractual obligation. The Home Office reserves the right to suspend or revoke Type Approval.

The operator must ensure a device is calibrated annually. Annual calibrations can only be carried out by the manufacturer or organisations approved by Home Office PSDB. The annual calibration is vital and a device is not within type approval unless the operator has the certificate of calibration. Most devices will also have a sticker applied to them showing the date of the last calibration or the due date of the next.

The annual calibration should not be confused with the necessary periodic checks of calibration of devices against known distances or speeds. These periodic calibrations are a fundamental part of the operator's procedures.

1.9 Does proximity to the start or the end of a speed limit on a particular section of road have any operational significance?

A speed limit starts or ends at the exact point on a road indicated by the relevant signs. There is no legal bar to the enforcement of a speed limit from that exact point. There are however operational constraints dependent on the device used. ACPO will not specify a minimum distance from the start or end of a speed limit from which enforcement can place. Enforcement may only take place where the operator is absolutely positive, and a court may subsequently be certain, the whole of the measurement of the speed took place within the speed limit. If there is any chance, whatsoever, that any of the measurement took place, or could have taken place, outside of the speed limit then that measurement will be disregarded.



Code of practice for operational use of enforcement equipment



Glossary of type approval terms

Attended Actively Operated

Refers to the operation of enforcement devices, which are Type Approved for corroborating the evidence of a police officer or other witness with regards to the circumstances of a detected offence.

Where the device can work automatically once set in operation, it is not sufficient for the officer to be in the vicinity of the device merely to ensure its safekeeping. The evidence of the operator is critical to the use of the device and the integrity of the evidence gathered.

Where a camera is added to the device, the images recorded by it are a contemporaneous record of the offences witnessed by the operator. Since there is no recorded independent secondary check of the primary speed reading, the mere presence of the camera does not allow the use of the device in an unattended or supervised mode

Automatic unattended operation

Refers to the operation of equipment mounted in a tamper proof housing and designed to operate automatically. Such equipment shall record an image of an offending vehicle together with the time, date and speed (if appropriate). In the case of speedmeters there must be a Home Office approved independent secondary check of the primary speed reading.

Supervised automatic operation

Refers to the operation of enforcement devices, which are Type Approved to detect offences automatically but require supervision to prevent loss or damage. Such equipment shall record an image of an offending vehicle together with the time, date and speed (if appropriate). In the case of speedmeters, as for unattended devices, there must be a Home Office approved independent secondary check of the primary speed reading.

Primary Speed Measurement

The evidential speed reading produced by a speedmeter. It is usually the result of two or more separate readings.

Secondary Check

The means of corroborating the primary speed reading which is totally independent of the mechanism by which the primary speed reading was calculated. An example is the use of two photographs taken at a known time interval with marks laid onto a road surface to engineering standards.



Code of practice for operational use of enforcement equipment



2. Airwave (TETRA) Radio and enforcement equipment.

ACPO Road Policing Enforcement Technology endeavours to ensure the advice on operating conditions is provided to eliminate the possibility of police equipment or third party equipment affecting the integrity and accuracy of enforcement equipment. Appendix "A" gives advice for all existing devices.

From October 2002 all new type approved equipment will be subject to the following advice:

Hand held attended actively operated TLEDs not operated within vehicles:-

- Can be operated to within 0.2m of a personal 1W TETRA radio and 1m of a 3W vehicle mounted TETRA radio.

All other attended actively operated TLEDs and automatic supervised TLEDs not operated within vehicles:-

- Can be operated to within 1m of a personal 1W TETRA radio and 3m of a 3W vehicle mounted TETRA radio.

This advice is offered on the basis that all forces will follow P.I.T.O. guidance and procure Airwave equipment with a transmit power rating of 1 watt (handheld) and 3 watts (vehicle mounted). More powerful radios are available but are not covered by this advice.

2.1 Third Party Interference

There is no risk of interference from third party systems if the recommended minimum separation distances are maintained.



Code of practice for operational use of enforcement equipment



3. Police (Health And Safety) Act 1997

Road policing enforcement must be carried out in compliance with legislation and guidance.

All devices referred to within this Code of Practice have been tested and conform to current safety parameters. Operators and road users may be exposed to unnecessary danger when technology is used inappropriately or outside guidelines.

All personnel must remain aware of the hazardous nature of such policing activity and the constant need for safe working practices.

Risk assessments must be completed for all enforcement activity and where the advent of new technology or changes in the working environment dictates such a need.



Code of practice for operational use of enforcement equipment



4. Operational Training

All training should be documented and a robust audit trail maintained to assist in the rebuttal of any challenge as to the competency of operators.

4.1 Objectives for Training Enforcement Device Operators

ACPO recommendations are that the duration of training should be a sufficient to enable an operator to qualify for the award of Certificate of Competence. The instruction of trainers must also be sufficient to ensure their competency maintains standards.

At the conclusion of the course the student will:

- Understand the basic principles of road policing enforcement technology as outlined in this document and manufacturers' instructions.
- Demonstrate their ability to safely carry out checking, accuracy tests and operating techniques applicable to devices used.
- Be competent in the presentation of evidence.

4.2 Additional Training Objectives For Time/Distance Devices

It is recommended that all training be carried out using similarly equipped vehicles with car-to-car communications. TETRA radios or GSM phones must not be switched on in the vehicles. At the conclusion of the course students will:

- Demonstrate an understanding of the principles and safe operation of the in car speed detection device(s).
- Be able to calibrate the device(s).
- Be able to carry out calibration checks.



Code of practice for operational use of enforcement equipment



5. Attended Actively Operated Devices: Presentation of Evidence

Any prosecution depends upon the integrity of the method of operation, accurate observations by the officer operating the device and their professional presentation of evidence, if challenged, before the Court. It is in this area that the integrity of the device and its operation will be closely scrutinised.

Operators should record evidence concerning the target vehicle, such as speed, direction of travel, etc. Additionally, they should note any other factor (such as the presence of any other vehicle in the vicinity), which may be used in defence when challenging prosecution evidence. (Criminal Procedure & Investigations Act 1996).

All evidence must be properly documented.

The evidence from attended actively operated equipment corroborates the operator's **prior** opinion the target vehicle was travelling in excess of the permitted speed limit for the road or class of vehicle.

If the operator has any doubt as to the validity of the reading obtained by the device in comparison to their personal estimation of the speed of the target vehicle, then they will stop the check.

Except in exceptional operational circumstances, devices should normally be operated from positions where they will be clearly visible to the public.

The target vehicle must be kept within direct sight of the operator of the device at all times throughout the period of observation and check.

Contemporaneous positive identification of the target vehicle must be made by the device operator.

Whilst no legal requirement exists for the accused driver to be shown the speed recorded on the device, they should be given the opportunity whenever this is possible. (*Westwater v Milton*, 1980).

A trained police operator must be aware of the basic technical functions of the device. However, it is not necessary for them to be technically qualified to give evidence on principles of the system nor the internal workings of the device. If such evidence is required, then the CPS should ensure an expert witness is called from the manufacturer or their agent.

The operator must be in a position to produce evidence, which supports their opinion that, at the time a device produced a record (for example on the visual display unit) the device was working correctly.



Code of practice for operational use of enforcement equipment

The proper application of all checking procedures coupled with the officers prior qualification and knowledge of the device, will satisfy a court that the device was working correctly.



6. Speed Detection Using a Speedometer Fitted To a Patrol Vehicle

This type of check, commonly known as the 'follow check' has been used by police forces for a number of years and is readily accepted by the courts and motoring public alike. If the speedometer is used to support the suspicion of the officer then it **must** be tested as detailed below.

6.1 Means of Check

A road policing vehicle must be fitted with a certified calibrated speedometer regularly tested in accordance with Force instructions.

The checking vehicle should be positioned to the rear of the suspected offending vehicle so as to maintain, throughout the check, an even distance between the vehicles.

Speedometer readings should be taken throughout, preferably related to readily identifiable points passed.

6.2 Minimum Distance

2/10 of a mile, is the minimum distance recommended by ACPO for such a check.

6.3 Speedometer Accuracy

The patrol vehicle speedometer should be checked for accuracy at the end of a tour of duty after detection of an offending vehicle.

Speedometer accuracy can be checked using: a certified measured distance with certified stopwatch or chronometer; or a rolling road type device; or against another Type-Approved device NOT fitted to the vehicle, e.g. laser or radar equipment.

6.4 Measured Distance

Each element of the checking procedure should withstand challenge, and where certified distances are used these should be laid to engineering standard. The evidence of the person creating a measured distance should be available.



Code of practice for operational use of enforcement equipment



7. Radar

7.1 The Doppler Principle

All radar speedmeters currently approved for use by United Kingdom forces rely on the Doppler effect for their operation.

The Doppler effect occurs when a wave source and an observer are in relative motion to each other the frequency of the waves appears to change. The frequency increases when the source of the waves and the observer approach one another and decreases when they move apart (Figure 1).

The Doppler effect can occur with any kind of wave; sound, light or radio, and is best described by imagining a listener standing on a railway platform hearing the siren of an approaching train. The frequency (pitch) of the siren heard by the listener is higher than that heard by the train driver. When the train has passed the frequency will sound lower to the listener. The effect is equally true for radio waves.

For a Doppler radar speedmeter, a signal consisting of a narrow high frequency radio beam is transmitted along the road. A vehicle approaching along this beam will reflect some of the signal back to the system. Because of the Doppler effect the frequency of the returned signal will be higher than the transmitted signal.

The meter receives the reflected signal and measures the difference in frequency. The change in frequency is proportional to the speed of the vehicle. The meter then converts this information into miles per hour and shows it on a display.



FIGURE 1

THE DOPPLER EFFECT EXPLAINED

THE SPEED OF A VEHICLE IS ARRIVED AT BY COMPARISON OF SIGNAL SENT AND SIGNAL RECEIVED

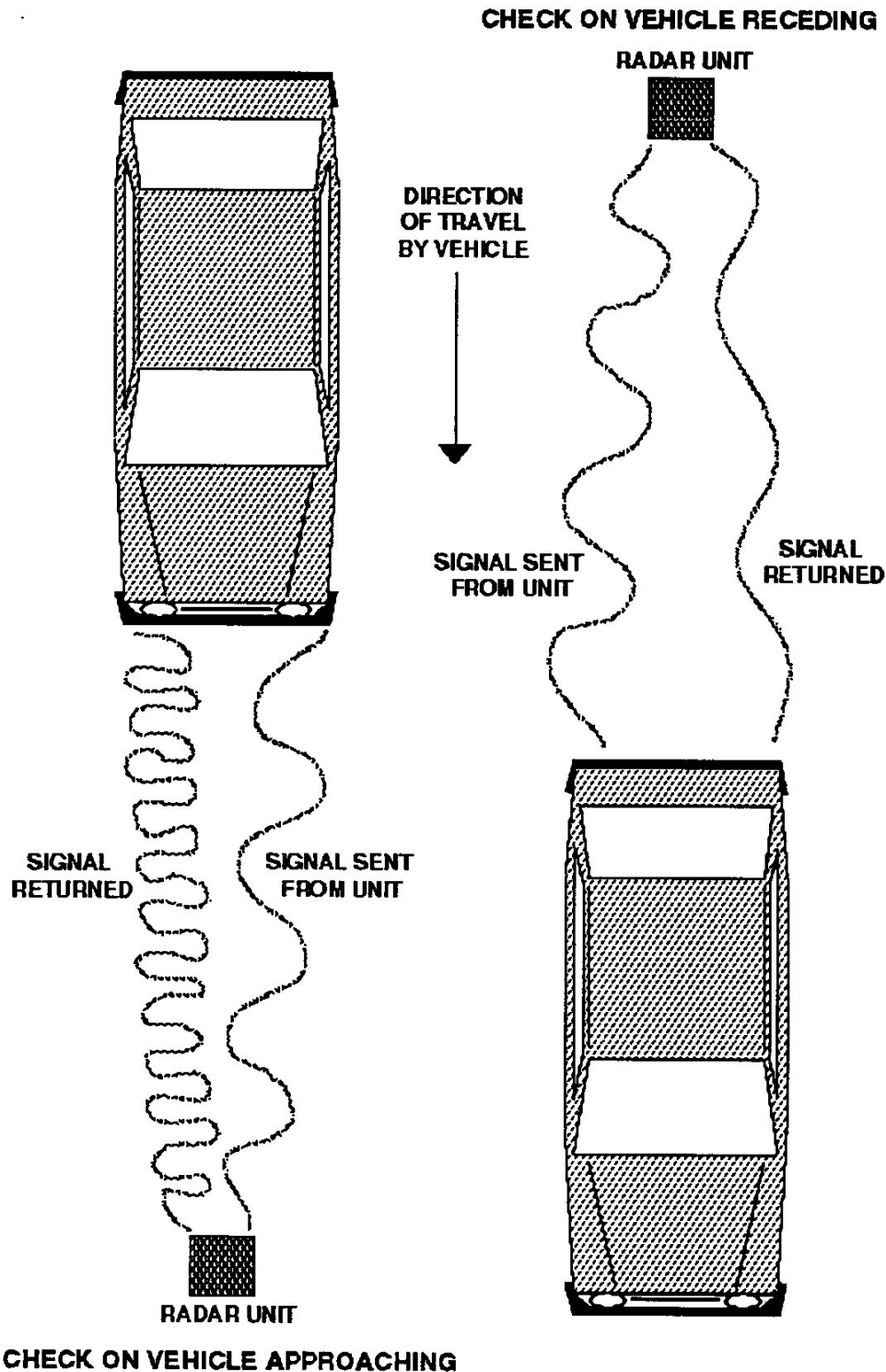



7.2 Radar Coverage

The meter will always display the speed of the strongest returned signal. When two cars of similar size are approaching the meter it **may** display the speed of the nearer vehicle.

The signal received by the radar not only depends on the distance of the vehicle, but also its size, so that a large lorry some distance from the meter may return a signal stronger than a small car closer to the meter.

The radar meter has an aerial which forms the radar signal into a beam so most of the signal is sent out directly ahead of the meter, but some of the signal spreads out on either side of the main beam. The coverage of the radar depends on several factors, including: (a) the radar power (b) receiver sensitivity (c) aerial characteristics (d) the size of the target vehicle (e) its distance from the observer, and (f) its position in the aerial beam

Figure 2 shows the effective detection range for different sizes of vehicle. It can be seen from the diagram that the coverage in terms of road distance and width depend on the size of the vehicle.

Different models of radar will have different coverage diagrams but Figure 2 may be taken as typical for hand held radars.

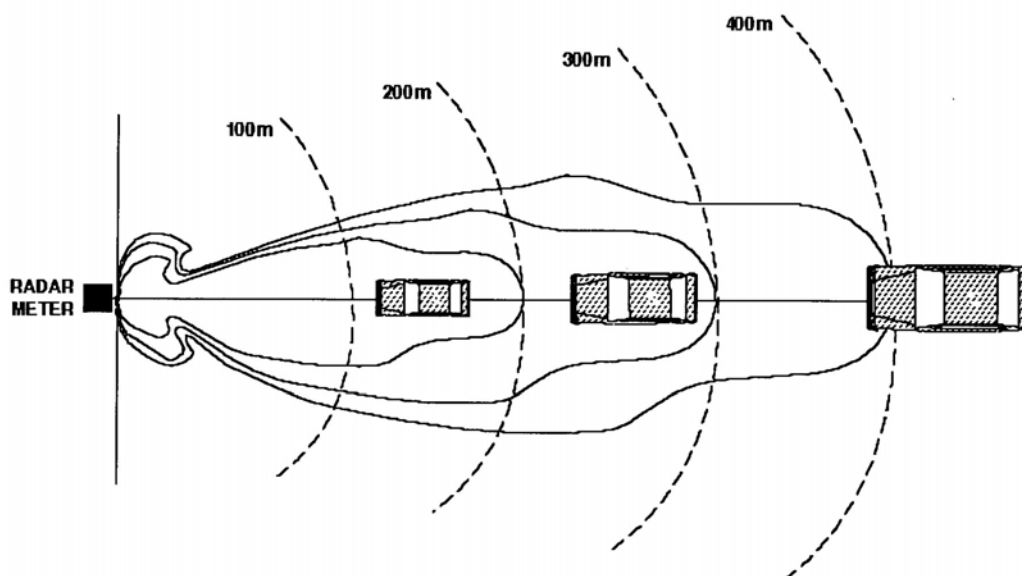

COVERAGE DIAGRAMS FOR A TYPICAL HAND-HELD DOPPLER RADAR

The figure shows three superimposed coverage diagrams. The radar meter can detect each vehicle within the boundary shown, vehicle A is within its coverage area, it will not register on the meter beyond 200m. The larger vehicle B can just be detected out to 300m. Vehicle C is just entering its coverage area.

This diagram shows the effective detection range for different sizes of vehicle. It can be seen that the coverage in terms of road distances and width will depend on the size of the vehicle. Different makes of radar will have different coverage diagrams, but the illustration above is typical of a hand-held radar speedmeter.



7.3 Cosine Factor

Radar will only record the true speed if the radar is in the line of the vehicle's path. The vehicle may be either approaching or receding.

If the radar is positioned at an angle to the path of the vehicle, the apparent speed of the vehicle is reduced. The reduction in speed is proportional to the cosine of the angle.

For an angle of 15 degrees a speed of 38mph will be recorded for a vehicle travelling at 40mph.

The cosine factor is always in favour of the driver.

Roadside radar devices have inbuilt electronic circuits to correct the cosine factor provided the unit is aligned correctly in accordance with manufacturer's instructions.

7.4 Site Selection

Health and Safety: Always choose a site that affords the operator and other road users maximum safety with regard to any potential hazard. The operator must consider the minimum distance a driver will take to react and brake safely to a standstill when stopping alleged offenders.

As described previously, the radar signal is reflected from a moving vehicle. The signal can also be reflected or scattered by stationary objects such as road signs, hoardings, stationary vehicles near to the radar, or pillar-boxes. As these objects are stationary, no Doppler effect should occur and no readings appear on the display.

However, these objects can act as radio 'mirrors' and reflect signals from moving vehicles outside the area of the coverage diagram (Figure 2). For example, the signal could be reflected around a bend in the road and measure the speed of a vehicle not visible to the radar operator.

Because of the scattering effect, signals returned to the radar in this manner will be very weak and far less than the signal returned from a vehicle directly in the radar coverage area. While it is extremely unlikely a reflected signal will have any effect while a vehicle measurement is being made, operators should always satisfy themselves as to the integrity of the check.

Sensible precautions should be taken to select a site free from reflecting objects and with a clear, unobstructed view of the road.

The ability of objects to reflect radar signals varies. A flat metal surface, such as a hoarding, will reflect more efficiently than a run of trees, which would absorb and scatter the signal.



Code of practice for operational use of enforcement equipment

To act as a radar mirror, objects may only need to:

- be at the correct angle
- rotate at the correct speed
- occupy a portion of the field of view
- be reflecting a fairly strong signal.

Always select a site with a clear view of the oncoming traffic and which is free of any large objects such as: bus shelters, large road signs, fences/crash barriers, stationary large vehicles.

To avoid multiple reflections the radar must not be operated from under a bridge or arch and should not be targeted through bridges, railway arches or concrete lined cuttings. Other types of device should be used.

The selected site should be assessed for reflections by facing the traffic flow and aiming the meter along the road when no vehicle is in view.

Traffic passing to the side and rear of the operator may cause a reading if a reflective surface is present. A different site **must** be selected if this could happen.

Radar equipment in the actively operated mode must not be operated for enforcement purposes in the central reservation of a dual carriageway or motorway. It may, however, be so operated when installed for unattended automatic use.

7.5 Summary

The site must be tested and shown to be clear of any obvious source of interference and reflectors.

The operator must have a clear view of the road.

The operator must be at the side of the road, facing the oncoming traffic.

7.6 Radio Interference

It is impossible to ensure complete immunity from radio interference. The best protection is the use of the speedmeter in the hands of a trained and certified operator who will be aware when interference occurs.

If radio interference is present the speed display may still show a speed reading. Some devices have in-built radio interference detectors which display a symbol or signal on the display. The reading may be steady, or erratic depending upon the type of transmitter. Interference effects will only occur



Code of practice for operational use of enforcement equipment

when the radar meter is close to the transmitter or the transmitter is very powerful. It is not possible to lay down strict criteria for safe operating distances from some transmitters but see below for TETRA radios. The strength of the interference depends on several factors, such as transmitter frequency, type of aerial and modulation system.

Police analogue radio **transmitters**, whether hand held or car mounted, must not be used at the moment a vehicle speed is being measured. While with analogue radios it has been perfectly safe to leave the receiver on, provided the volume level is at a usable minimum, with TETRA digital radios it is necessary to turn the power fully off or utilise the transmission inhibit switch if fitted, unless the separation given in Appendix A can be maintained. The use of a repeater radio in the vicinity of a radar speed meter must be avoided.

When selecting a casualty reduction site, **treat with extra caution** places with view of: high voltage overhead lines, transmitting masts or tower, airports or harbours, and any other place where high power radar transmitters may be expected to operate.

Never point a speedmeter at a civil or military aircraft, vessel or armoured vehicle. Many military aircraft, vehicles or vessels have target acquisition detectors, some of which initiate automatic counter measures.

With the current popularity of Citizen Band radio transmitters, mobile telephones and satellite or radio communication systems, it may be difficult in a suburban street to tell the difference between transmitting aerials and domestic receiving aerials.

It is important, therefore, to ensure no interference is present by carrying out 180° and 360° repeated checks in accordance with the instructions for a particular device. Checks must be made when the device is set in the measuring mode and with no vehicles present in the field of view, to verify the meter display is blank and/or the radio interference indicator is not indicating the presence of interference.

Do not use GSM phones when using any radar device.

Some meters are fitted with RFI protection circuits. The operation is described in the operator's handbook relevant to the device.

7.7 Radiation Hazard

Health and Safety: Radar devices having United Kingdom Home Office Type Approval comply with standards that are designed to ensure personal safety when operating the device. The maximum level of radiation when transmitting is below the United Kingdom recommended level and the devices can be considered absolutely safe for police use. No particular precautions



Code of practice for operational use of enforcement equipment

are considered necessary. However, to avoid even low-level exposure it is recommended that the radar aerial should not be held closer than 25cms to the body.

The National Radiological Protection Board lay down guidelines in respect of maximum exposure levels to radiation. The Home Office Type Approval requirements demand these levels are not exceeded.

7.8 Care and Maintenance

A radar device is a precision instrument. It has been constructed robustly but must be carefully and sensibly handled.

Protective carrying cases should be used when the device is not in operation. Any power or display cables **MUST** be disconnected before a device is re-packed.

Should a device be dropped or damaged it must be checked immediately using the standard calibration method. Any apparent defects must be reported and the device taken out of service.

The charging and maintenance of power packs is governed by manufacturer's instructions.

Repair and maintenance must only be undertaken by a competent organisation approved by the Home Office, manufacturer, or appointed agent.

7.9 Annual Calibration

(a) Any device used operationally **MUST** have a current calibration certificate.

(b) The manufacturer, appointed agent, or a suitably qualified technician who has been approved by PSDB and appears in their register of approved calibrators, shall **ONLY** carry out repair or calibration. Such persons shall keep accurate records which shall be open to inspection and will comply with the specifications and conditions laid down by PSDB.

(c) Radar speedmeters must be calibrated at a minimum interval of once a year and a certificate issued to this effect and held by the police. A visible sticker showing the date of calibration may be fixed to the meter.

(d) At the time of annual calibration, the device should be certified as not having been changed in specification from the format in which it was Type Approved.



Code of practice for operational use of enforcement equipment



8. Parabolic Radar

This type of device was Type Approved on 24 May 1995.

It is designed to be used in an 'over the road' configuration from a fixed installation mounted on a bridge or gantry. It emits a focused beam at a predetermined angle along a specified lane of the carriageway.

It is only approved for use with specific variable speed limit signs and therefore currently used only within the M25 Controlled Motorway Project.



Code of practice for operational use of enforcement equipment



9. Operating Hand-Held Radar

9.1 Health and Safety

The operator should always choose a site, which affords them and other road users maximum safety with regard to any potential hazard and must consider the minimum distance a driver will take to react and brake safely to stop. High visibility clothing must be worn by those officers working at the roadside.

Hand-held radar devices must not be used indoors.

In operational use the operator and the device must be outside any vehicle.

The vehicle must not be used as a power source.

The Type Approval process acknowledges the accuracy of the device together with its self-checking systems. In that respect, it is vital that all radar devices are checked in accordance with the manufacturers instructions at the start and conclusion of a tour of duty. These checks will be recorded and noted as part of the evidence as to the integrity of the machine. Additionally, at each speed detection site, the officer will note that when switched on, the device self-checked and operated correctly. The need for a patrol car to be summoned to drive through the site to check accuracy of the device is no longer required.

Hand-held radar speedmeters should only be operated by an officer on foot.

The only enforcement situation should be when one vehicle is isolated in the field of view of the radar device and the operator.

The device should be pointed directly at the approaching or receding target vehicle, almost parallel to the roadway, eliminating any significant up or down tilt.

Once a reading has appeared on the display, the radar device should be held steady, pointing along the road for a duration of **not less than three seconds**. During this period a 'steady' reading must be obtained which equates to the observations of the operator.

'Steady' in this context can include accelerating or decelerating readings, e.g. readings of 45-45-46-47, or 47-46-45-43 are acceptable.

If the reading jumps by several mph, e.g. 47-40-35-47, or if the operator has any doubt as to the validity of the reading, the check must be aborted.

Once the operator is satisfied that the reading showing on the display corroborates their personal observation's and is the speed of the target



Code of practice for operational use of enforcement equipment

vehicle. Where appropriate the trigger button must be activated to lock the display **whilst this reading is still visible**.

The reading can be cleared following the manufacturers instructions for the particular device being used.

9.2 Distance Awareness

When operating the device and during the preparation and presentation of evidence, it is essential to visualise distances that will be travelled by the target vehicle during each check.

At 60 mph the target vehicle will cover 80.4 metres in 3 seconds. One also has to take into account the observation time for an opinion to be gained. To cause the vehicle to stop will require another 73.1 metres. It is therefore imperative that these matters of physical fact be recognised and understood.

9.3 Distances to stop (source Highway Code)

Speed in mph in radar display	Distance travelled in 3 seconds (metres)	Stopping Distances (metres)	Total distance to stop at operator (metres)
30	40.2	22.8	63.0
35	46.9	29.3	76.2
40	53.6	36.5	90.1
45	60.3	44.5	104.8
50	67.0	53.3	120.3
55	73.7	62.8	136.5
60	80.4	73.1	153.5
65	87.1	84.2	171.3
70	93.8	96.0	189.8



9.4 Multiple Vehicles

Radar speedmeters are designed to measure the speed of one vehicle at a time. Should there be more than one vehicle present in the radar field of view, it is possible for the device to detect two different signals, and alternately display different speeds in which case the check **must** be aborted.

With more than one vehicle (especially when they are of a similar size) within the range of the radar, the meter may read the nearer vehicle, but not necessarily, since the reflected signal from a vehicle is very complex and fluctuates rapidly as the view of the vehicle changes slightly. **An operator must not make detections for prosecution when more than one vehicle is within the radar detection range.**

It is quite possible for the signal from a large vehicle some distance behind a smaller vehicle to override the signal from the nearer vehicle.



Code of practice for operational use of enforcement equipment



10. Operating Roadside Radar

Fixed site and mobile devices can measure either approaching or receding traffic by the operation of a switch on the unit as per manufacturer's instructions.

Speedmeters will operate at all times of day or night and in most weather conditions. (The equipment is Type Approved from -10° to +50°c).

10.1 Choice of Site - Health and Safety:

The operator should always choose a site which affords them and road users maximum safety with regard to any potential hazard and must consider the minimum distance a driver will take to react and brake safely to a standstill when stopping alleged offenders. High visibility clothing should be worn.

Satisfactory operation of the device depends on the correct positioning and alignment of the radar. It should be positioned as near the traffic flow of interest as is convenient and it should face a straight section of road.



Code of practice for operational use of enforcement equipment

The radar is primarily intended to be operated at the side of the road adjacent to the traffic flow to be monitored, with that traffic flow either approaching or receding from the radar, as shown in Figures 3 and 4.

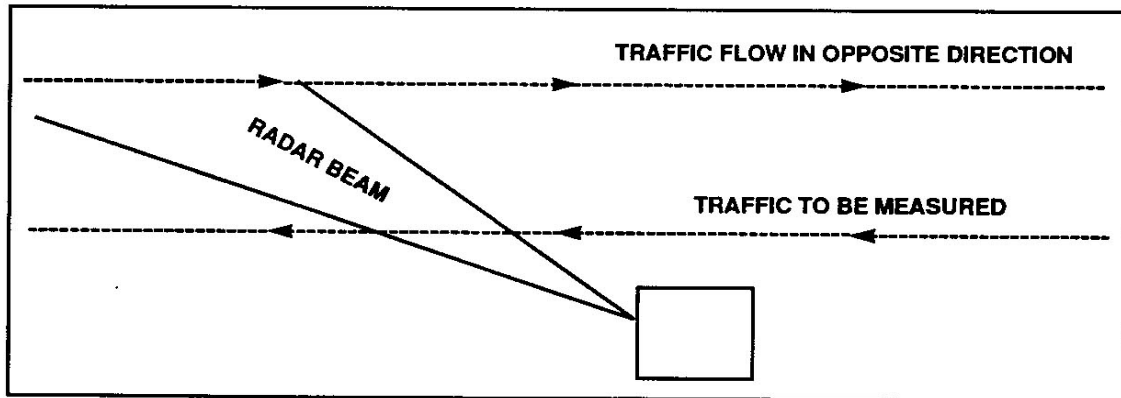

FIGURE 3. RADAR SET UP TO MEASURE SPEEDS OF TRAFFIC RECEDING FROM THE RADAR

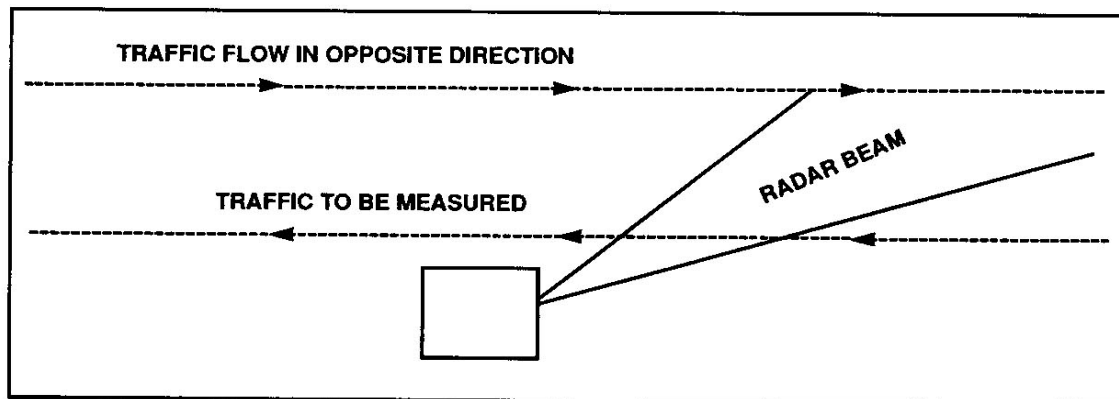

FIGURE 4. RADAR SET TO MEASURE SPEEDS OF TRAFFIC APPROACHING THE RADAR



Code of practice for operational use of enforcement equipment

It should be noted that certain models will also detect the traffic moving in the opposite direction to that of interest. The use of the range control will minimise the incidence of unwanted readings from traffic remote from the radar.

Certain models will only respond to vehicles travelling in the direction selected by a control switch on the device.

It is possible to monitor traffic speeds in both directions or to use the radar on the side of the road remote from the traffic flow of interest but care must be taken that small vehicles in the furthest lane are not out of range of the radar.

The normal practical maximum width of road for detection of all vehicles is three lanes but the manufacturer's operational handbook will provide specific guidance.

Radar equipment in the attended mode must not be operated for enforcement purposes in the central reservation of a dual carriageway or motorway when the two carriageways are in use. It may, however, be so operated when installed by manufacturers for unattended automatic use within cabinets.

10.2 Setting up the Radar Meter and Operation

The device must not be operated from within a vehicle.

Setting up should be in accordance with the manufacturer's instructions for the unit concerned.

Due to the possibility of radio interference the device **must not be used** for speed enforcement purposes with a display extension lead other than that supplied by manufacturers and agreed with PSDB during Type Approval.

Checks as per manufacturer's instructions must be carried out at each site prior to and after operation. In addition to the checks recommended by the manufacturer, the display/test display button should be operated to ensure that the digital display on the device is in perfect working order.

The accuracy of mobile devices **must** be checked by driving a vehicle with a calibrated speedometer through the beam at a predetermined speed, at the commencement and completion of operations at each location (the speed being compatible with the site being checked).

Readings should only be considered valid if the operator(s) are sure that only one vehicle passed through the beam. It is therefore important that the operators have a clear view of both the area of road covered by the beam and of the speed display.



Code of practice for operational use of enforcement equipment

The road area covered by the radar should be in view of the operators. Where vehicles are being stopped at the time, if physically possible, the site should be selected so that the speeding vehicle, the display and stopping officers can all be seen clearly by the radar operator.

The ideal enforcement situation is when only one vehicle is isolated in the radar field. Some speedmeters will automatically reject a reading when more than one vehicle is in the beam.

If there is more than one vehicle present, the operators must measure only one vehicle and they must ensure that the proximity of other vehicles is such that a clear reflected signal will be obtained of the target vehicle.

Under no circumstances must other moving vehicles, travelling in any direction, be between the operators and the target vehicle.

If for any reason the operators have any doubt as to the validity of the reading, the check must be abandoned.



11. Time/Distance Type Devices

The time/distance method of speed detection may be utilised when operating Home Office Type Approved or ACPO approved devices. Only operators who have demonstrated an ability to safely perform five examples of each of the operating methods taught will be a certificated operator. During qualification no one check may exceed a two miles per hour error and in the case of Vascar, Police Pilot or Speed Marshall the average error must not exceed 0.75 mile per hour.

The manufacturer's instructions must be adhered to in respect of switch operation and methods of calibration.

11.1 Home Office Type Approval

Until late 1996 time/distance calculating equipment did not require Home Office Type Approval and its use is sanctioned as 'ACPO approved'.

A number of these devices are capable of being linked into video recording equipment. This in no way affects the operation of the time distance device but merely provides pictorial evidence of offences observed through the camera and evidence on tape of the operation of the time distance device. The operator's evidence is critical.

11.2 Basic Principles

The detection of speeding offences using the equation: **Speed = Distance divided by time** is a long established practice. Initially this was carried out by the use of a certified stopwatch and the odometer of the patrol car. Whilst this principle remains, technology has allowed for the introduction of sophisticated equipment, which has proved to be far more efficient and accurate. The operation of the devices simply involves the operation of a distance switch and a time switch, in the appropriate sequence. This calls for a high level of operator accuracy and, in order to achieve it, a good deal of practical experience is required.

Where a vehicle is, in the opinion of a police officer, travelling at an excessive speed the device is used as corroboration.

The checking of a target vehicle's speed can be done by a number of methods.

In order that this can be done, the target vehicle must be checked between two reference points best defined as 'either a permanent or temporary identifiable point on or near the carriageway':

(a) Which either casts a shadow so as to strike a moving vehicle, or which is so placed that the shadow of a moving vehicle strikes it or its shadow; **or**



Code of practice for operational use of enforcement equipment

(b) Where there is physical contact between the road wheels of the moving vehicle and a reference point; e.g. change of surface, drain; **or**

(c) Where the target vehicle and the police vehicle are side by side.

There are five alternatives

- a moving shadow on a stationary object or a mark on the road surface;
- a moving object on a stationary shadow or a mark on the road surface;
- a shadow-to-shadow contact;
- physical contact of vehicle wheels with reference point;
- both vehicles are side by side;

By using reference points, which fit this definition, any uncertainty can be eliminated.

It is important to remember the police vehicle **must** pass between the same points as the target vehicle. This is essential as the distance information is taken from the police vehicle.

When the police vehicle has travelled between the two points and the distance switch operated, on at the first point and off at the second point, the device then knows the distance between the points. As the target vehicle travels between the same two points, the time switch is operated. The switch being switched on at the first point and off at the second point. The device now knows the time the target vehicle took to travel between the two points.

The device now has both parts of the equation required to calculate the target vehicle's average speed. This is done in a fraction of a second and the result is then visible on a digital display.

If for any reason the operator has any doubt as to the validity of the check, it must be abandoned.

11.3 Types of Check

11.3.1 Follow Check

This type of check is carried out when the police vehicle is following the target vehicle. As the target vehicle passes the first reference point, the time switch is turned on. As the police vehicle passes the same reference point, the distance switch is turned on. As the target vehicle passes the second reference point, the time switch is turned off.

The device now knows the time the target vehicle took to travel between the



two reference points.

As the police vehicle passes the second reference point, the distance switch is turned off. The device now knows the distance between the two reference points that the target vehicle has travelled.

11.3.2 Pre-Fed Distance Check

This type of check is carried out when the police vehicle travels between the two reference points. Turning the distance switch on at the first point and off at the second point.

The police vehicle then parks in a position that the two reference points can be clearly seen by the operator.

The device has the distance between the reference points stored. As a target vehicle passes between the points the time switch is turned on and off. The device can then calculate the speed. Providing the distance information is not cleared from the device the police vehicle can remain parked and, by clearing the time information only, another target vehicle can be checked.

11.3.3 Being Followed Check

This check is carried out when the police vehicle is travelling in front of the target vehicle that is approaching from behind at a speed, which is excessive.

The police vehicle will travel between the two reference points, with the operator turning the distance switch on and off. The device now knows the distance travelled.

As the target vehicle, still approaching from the rear, passes the same points the time switch is turned on and off. The device now knows the time taken to travel between the reference points. The device knows the distance and time and can calculate the speed. **NB When using this method operators should guard against any suggestion of provoking another driver to commit the offence especially if the police vehicle is unmarked.**

11.3.4 Crossing Check

This check is started when the police vehicle is stationary.

As the target vehicle passes the first reference point, the time switch is operated. The police vehicle then moves off behind the target vehicle, operating the distance switch as the police vehicle passes the same reference point.

With the police vehicle now following the target vehicle and both time and distance switched on, the completion of the check is the same as the 'follow



check'.

11.3.5 Dial in Distance Check

This mode enables a known distance previously measured by the device to be fed into the device computer without the need to drive again over the route. Simply record the distance on the same push button switches as used for calibration purposes. This procedure can also be used with the control module removed from the car and plugged into the portable battery pack.

Particular care must be exercised where shadows are used as these will change with the movement of the sun

The minimum distance for any check is generally 1/8 or .125 of a mile. However checks over a shorter distance, down to an absolute minimum of **0.07** of a mile, are permissible under the following circumstances:

- (a) This minimum distance is only for Pre-fed or Dial in Distance Checks.
- (b) The reference points at both the start and end of the check are physical features on the road surface, which provide a clear and visual contact (e.g. white line/change of surface) **not** shadows.
- (c) The maximum speed limit at the site does not exceed 40mph.

Trainers are to be satisfied that operators carrying out reduced distance checks are capable of performing the function professionally

11.4 Calibration

In order to maintain accuracy these devices must be calibrated in accordance with the manufacturer's instructions. Full calibration must be carried out:

- (a.) on initial installation,
- (b.) following removal and reinstatement,
- (c.) following the fitment of new tyres, and
- (d.) in any case at weekly intervals.

In order to establish the ongoing accuracy of the device a check **must** be carried out at the commencement of each tour of duty and at the end of that tour of duty if it has been used to detect an offence. This will be either:

Calibration check (all types) or (b) Double Switching (Vascar/SPDM).

If the device is found to be inaccurate, then not only must the defect be remedied but also any offences detected since the previous accuracy check



should be reviewed, as it is not known at what point the equipment became defective.

11.5 Radio Interference

Police radio **transmitters**, whether hand held or car mounted, must not be used at the moment a vehicle speed is being measured. While with current analogue radios it has been perfectly safe to leave the receiver on, provided the volume level is at a usable minimum, with TETRA digital radios it is necessary to turn the radio off unless the transmit inhibit mode (if fitted to the radio) has been enabled.

Do not use these devices when any GSM phone is on and in the vehicle.

11.6 Unattended Automatic Time Distance Devices

Currently the Specs (SVDD) system is the only Home Office Type Approved automatic unattended device which utilises time over a distance rather than measuring a spot speed. This distance is sometimes referred to as a 'baseline'.

This device is set up by the manufacturer and then operated by the police.

The initial calibration and commissioning of the site must ensure evidence is available which shows vehicles' speeds are calculated against the very minimum distance any driver could have driven between the start and finish of the measurement zone.

Where this type of device is used in temporary roadworks, e.g. on motorway contraflows, it is quite common for the traffic management layout to change at intervals. Each time this happens the operation must be reviewed and the evidence adduced to prove the shortest possible distance any driver could travel through the monitored zone.



Code of practice for operational use of enforcement equipment



12. Chronometers

Several types of chronometer have been approved by ACPO for use in detecting offences of excess speed. They function by having a known distance pre-fed into them, and the time taken for the target vehicle to cover that distance is then measured in the same manner as a pre-fed check or dial in distance check using time/distance devices.

Since the operator has no means of checking the accuracy of the distance used, chronometers should only be used at locations where:

The distance has previously been measured to engineering standards

AND

Both reference points to be used in the check are permanent marks or features clearly visible to the operator.

12.1 Radio Interference

Due to the wide variety of available electronic chronometers, they have not been tested against digital radios at the time of publication. Interim guidance is that speed checks should not be carried out whilst an analogue radio is transmitting or a digital radio is turned on without the transmission inhibit switch being activated. Do not use in a vehicle when a GSM phone is turned on.



Code of practice for operational use of enforcement equipment



13. Sensor Operated Roadside Speedmeters

13.1 Introduction

These devices offer a method of checking vehicle speeds on the road by the use of either electrical Piezo Co-Axial cables or hollow rubber tubes fixed across the carriageway at right angles to the flow of traffic.

The sensors are set (as prescribed by manufacturers) at a specified distance, and the instrument simply measures the time taken to cover that distance and computes the average speed of the vehicle.

The Piezo sensors may be embedded in housings set in the road surface (sub-surface sensors) Connecting cables lead from these permanent sensors to a post at the roadside where the speedmeter can be connected.

With either of these types of sensor the pressure of the vehicle's road wheels passing over it is converted into an electrical pulse used to stop and start timing counters in the device. The values captured are used to calculate and display the average speed.

All such devices are subject to Home Office Type Approval and calibrated annually by their manufacturer or UK agent. A certificate of this must be issued and the date of last calibration must be clearly displayed on the equipment.

Operators must be aware of the potential for certain axle configurations to create artificial readings. Compliance with proper operating procedure will ensure no inappropriate prosecutions being mounted.

13.2 Site Selection And Safety

Safety to both operator and public is fundamental and overrides any other factors in site selection.

All operators setting up sites will wear high visibility clothing at all times. Safety goggles should be worn when nailing sensor fixings into the road surface. Operators should ensure that such fixings do not cause danger to other road users and are removed at the end of the check.

It is important that a sufficient and safe stopping distance is allowed between the check site and stopping officers. Distances will vary according to differing site features and weather conditions. Stopping officers will wear high visibility clothing at all times.

The site must be selected so that the operator is in a position to form an opinion that the target vehicle is exceeding the speed restriction for that road. **(Unless the device has an approved secondary check, the speed**



registered on the device only corroborates the operator's opinion).

The operator must ensure that only the target vehicle is crossing the road sensors at the time of the check and no other external interference occurs.

13.3 Checking Procedures Prior To Use

Internal calibration checks.

Sensors installation and check procedure, including intermediate sensor tension checks.

When using a system incorporating air tubes care must be taken to ensure that all tubes are of an identical length.

The Type Approval process acknowledges the accuracy of the device together with its self-checking systems. In that respect, it is vital that at the start or conclusion of a check, all sensor devices are checked in accordance with the manufacturers instructions. For all temporary installations, at least one drive through check against a calibrated speedometer shall also be made. At sites using sub-surface sensors, a drive through check should be undertaken every six months at least and whenever there are signs of sensor damage or deterioration. Where it is not possible to undertake a drive through, the check may be made using another independent type approved device and comparing readings. These checks will be recorded and noted as part of the evidence as to the integrity of the machine and the data so produced.

The device **must be** within its annual calibration period.

Where sub-surface sensors are used they must be examined for any sign of damage or deterioration. The amplifier board and the connecting sockets or plugs must be inspected for signs of damage or interference.

13.4 Sensor Installation On Site

The manufacturer's instructions should be adopted for sensor installation.

Safety goggles must be worn if nails are used as masonry or road nails can shatter.

Road fixings other than those of a permanent nature should always be removed at the conclusion of the check.

Use only those sensor cables supplied by the manufacturer for use with the device.

13.5 Radio Interference

Police radio **transmitters**, whether hand-held or car mounted, must not be



Code of practice for operational use of enforcement equipment

used at the moment a vehicle speed is being measured. While with current radios it has been perfectly safe to leave the receiver on, provided the volume level is at a usable minimum, with digital TETRA radios it is necessary to turn the power fully off or utilise the transmission inhibit switch, unless the separation given in Appendix A can be maintained.

GSM phones must not be used at the moment a vehicle's speed is being measured. Where it is possible for the speedometer to be used inside a vehicle this must not be done where a GSM phone is on in the vehicle.



Code of practice for operational use of enforcement equipment



14. Laser/Optical Speedmeters

14.1 Introduction

Laser/optical devices are capable of being manufactured for hand-held, vehicle mounted (when stationary) or roadside use in both attended and unattended/automatic mode, with or without camera attachments.

The handheld devices, on occasions, **have the appearance of a firearm**. It is therefore important that this fact is borne in mind when operating such units. The operator must be clearly visible to the public and the target vehicle throughout the check. Devices should be operated in accordance with manufacturers instructions.

There are two automatic/tripod-mounted devices Type Approved – namely the AutoveloX 104/C-2 and Leica XV2. Neither have a secondary check and so although automatic, **they are both approved only for attended actively operated use**.

The AutoveloX operates from a tripod at the roadside or mounted on the rear window of a parked vehicle and point two laser beams down on to the nearest traffic lane. It operates similarly to a sensor device, detecting when a vehicle reflects the beam instead of the road surface.

The Leica XV2 operates on a tripod (but may be hand held) automatically using a pulsed laser beam in a similar way to hand held laser. However the beam is diverged and the vehicle measured in a limited distance window, starting when the vehicle is first detected at a distance of 50m or less. The vehicle is not tracked even if the device is hand-held. It is used on approaching traffic only and video recorded.

14.2 Hand-held

The hand-held device functions by emitting pulses of infrared laser beams, which are targeted at the vehicle whose speed is being measured.

Measurement of speed is performed by aiming the device at the target vehicle in the area around the registration plate and where necessary pressing the trigger or button. It is important that the beam is held steady on the target area to avoid any 'slip factor'. When sufficient pulses of light have been emitted and have returned, within the in built tolerances and checks, then a reading is displayed on the device. The speed recording can be locked into the display by activating the trigger/button in accordance with manufacturer's instructions where necessary.

Devices are capable of recording approaching or receding vehicle speeds, this fact being clearly differentiated by the speedmeter.



Code of practice for operational use of enforcement equipment

To assist the operator's identification of the target vehicle the meters have electronic sighting devices (currently either 'red dot' telescopic or 'reticule sight' on head up displays), together with audible 'locked-on' tones on some devices.

Operators should bear in mind the device confirms and corroborates their prior personal observations and opinion.

Certain hand-held laser speed detection devices have the ability to establish speeds of vehicles by calculating the time it takes a vehicle to travel over a known distance whilst in the time/distance mode.

The time, distance function must be operated in accordance with manufacturer's instructions and this Code of Practice.

Laser or optical hand-held devices may be used from within a vehicle provided there are no radio transmissions during the measurement. Any GSM phones must be turned off and any TETRA radios turned off unless they have a transmission inhibit switch, which is activated.

The beam must not be projected through glass or mirrors.

The power source must not be taken directly from any vehicle but always from the type approved independent supply.

14.3 Range

Hand-held devices are capable of measuring vehicle speeds from a minimum range of 50 feet to a maximum of 2,000 feet and recording speeds from a minimum of 5mph to a maximum of 155mph. Operators should avoid carrying out measurements for enforcement purposes at the extremity of the measurement field. Clearly the steadiness of sighting of the hand-held device affects operating range, but does not affect accuracy. In any case the device will not display any speed reading unless a proper 'lock-on' has occurred.

Heavy rain, spray or mist may reduce the range of the laser but will not effect the speed measurement.

14.4 Cosine/Angular Effect

The hand-held laser will only record the true speed if it is directed along the path of the target vehicle. The vehicle may be either approaching or receding.

If the laser is positioned at an angle to the path of the target vehicle, the displayed speed is less than its actual speed. This reduction in speed is proportional to the cosine of the angle.

The angular effect or cosine error is always in favour of the target vehicle,



whether the device is operated in the horizontal or vertical plane.

When operating hand-held devices from the roadside the operator should be within 10 feet of the edge of the carriageway and beyond the minimum operating range (i.e. 50 feet).

When operating hand-held devices from an overbridge, the operator must stand where possible over the centre of the carriageway being checked. In respect of minimum range, the operator must carry out a height check from the level of operation to the road surface directly below then multiply this by a factor of ten. This figure becomes the minimum distance for operation.

Health and Safety. Never point a laser speedmeter at a civil or military aircraft, vessel or armoured vehicle. Many military aircraft, vehicles or vessels have target acquisition detectors, some of which can initiate automatic counter measures.

14.5 Eye Safety

All laser devices fall within 'Class 1', which is the lowest classification of laser products in terms of relative potential injury to health. The 'Class 1' devices are safe for human exposure based upon current medical knowledge.

There are no special requirements except for principles of common sense, i.e.

(a) **Do not** stare directly into the beam.

(b) **Do not** stare at beam using binoculars, telescope, night sight, or other optical gain devices. (Prescription eyeglasses, bifocals, etc. are not considered optical gain devices as they serve only to correct the focus of the eye to normal human vision.)

14.6 Care and Maintenance

Periodic cleaning of external optical surfaces is recommended only when necessary, if evidenced by degradation in performance of unit or by visible contamination.

Cleaning should be undertaken in accordance with the manufacturer's guidelines.

Instrument should never intentionally be pointed directly at the sun or any other source of intense light; doing so may cause degradation of the sensitive receiver resulting in loss of performance (vehicle headlights do not affect the device).



14.7 Calibration/Testing

The device **must be** currently within its calibration period.

Due to the nature of the medium and systems used, these devices are continually self-calibrating.

Calibration verification is carried out:

- (a) By the device itself during its built-in tests upon being switched 'on'
- (b) During and as part of the start and end of tour checks. A record of these checks will be made (i.e. in pocket note book).

Should a calibration defect arise, the device **must** be returned to the manufacturer or certified authorised agent before further use.

The manufacturer shall annually calibrate a speedometer or his agent and a certificate should be issued to this effect and held by the police. A visible sticker showing the date of calibration should be fixed to the meter.

The type-approval process acknowledges the accuracy of the device together with its self-checking systems. In that respect, it is vital that at the start and conclusion of a tour of duty, all laser devices are checked in accordance with the manufacturer's instructions, and will include alignment and distance checks.

These checks will be recorded and noted as part of the evidence as to the integrity of the machine and the data so produced. Additionally, at each speed detection site, the officer will note that, when switched on, the device self-checked and operated correctly.

Where the operating design of the laser is such that a static distance check cannot be carried out the device must be checked against a calibrated speedometer by a drive through during the tour of duty during which the device is used.

The use of a patrol car to drive through each site to check the accuracy of the device is no longer required.

14.8 Radio Interference

Police radio **transmitters**, whether hand-held or car mounted, must not be used at the moment a vehicle speed is being measured. While with current analogue radios it has been perfectly safe to leave the receiver on, provided the volume level is at a usable minimum, with digital radios it is necessary to turn the power fully off or use the transmission inhibit switch, unless the separation given in Appendix A can be maintained. The use of any repeater



radio in the vicinity of a laser speed meter must be avoided.

GSM phones must not be turned on when a laser speedmeter is in use.



Code of practice for operational use of enforcement equipment



15. Cameras in, or attached to, enforcement devices

15.1 Introduction

This section deals with evidence and records made from video or camera attachments approved as part of, or for optional use with, specified Home Office and ACPO approved devices.

The devices in these combinations of equipment may be used separately where approval for such separate use has been given, e.g. Auto-vision and DS2.

The absence of a camera will in no way affect the type approval of the device should non-photographic operation be decided upon. Where a camera is attached to a Home Office approved device, the camera must have Home Office Type Approval for use in conjunction with that particular device.

If a camera attachment is used for recording purposes in the attended mode, one photograph will suffice as the device only corroborates the witness's opinion.

If the device is Type Approved for unattended/automatic use, any camera(s) will form part of the Type Approved device and used in conjunction with an approved second independent method of speed measurement. This secondary check is required in order to provide a further check on the accuracy of the device. No secondary check is required for red light cameras since the two images required by Type Approval provide sufficient check on the movement of offender's vehicle.

15.2 Criteria for Safety Camera Site Selection

All camera-attached devices have the potential to deal with large numbers of alleged offenders and as such are powerful tools in the drive to reduce road death and casualties.

Equally, they can be wrongly viewed as a revenue-gathering instrument if poorly located or if the relevant casualty reduction strategy is poorly 'marketed'.

Police forces must liaise closely with highway authorities and other members of casualty reduction partnerships in respect of proposed installations. Any location where static or mobile camera enforcement is to be used must be chosen on the basis of the following factors:

- a recognised KSI collision problem
- the causes of the KSI collisions, or a major factor in the severity of injury, must be illegal excess speed or red light running



Code of practice for operational use of enforcement equipment

- a robust review of the site and surrounding roads indicates enforcement is the best available option with **the sole intent being to reduce casualty figures by means of influencing driver behaviour.**

In this respect forces should keep in mind the considerable benefit of media involvement by advertising their commitment to such schemes both on a local and force basis.

Police forces should ensure that there is continual discussion (in line with the principles laid down in this section) with highway authorities in respect of the siting and installation of permanent sites for the use of automatic devices and that sites are selected in accordance with Department of Transport, Local Government and the Regions advice issued to Highways Authorities. That advice is repeated in Home Office Circular 38/1992.

The provisions of paragraph 15.2 should also be applied in respect of those locations where mobile casualty reduction measures will be utilised.

This liaison should also extend to residents living near sites as experience has shown that the activation of the flash facility has caused annoyance particularly at night.

15.3 Attended Actively Operated Devices

Where the equipment is only type approved for attended actively operated, the camera attachment does not affect the procedures for the operation of the device. The operator must check the operation of the device for each offence. The device is operator critical (see glossary) for each and every offence and **cannot be used in an unattended/automatic or attended/automatic mode merely because a camera has been attached.** The camera should be in the operational mode to record the relevant test runs by a police vehicle with a calibrated speedometer. A check of the accuracy of the equipment should be carried out at least once during each period of operation.

15.4 Unattended/automatic Devices

Installation

Roadside furniture and equipment must be installed in accordance with manufacturer's instructions and relevant highway safety legislation.

Care should be taken to ensure that the presence of the equipment does not create a road safety problem and that road signs and the like are not obscured or their effectiveness diminished by the equipment.

Care should be taken to ensure the camera housing is not obscured by signs or foliage to prevent the mistaken perception cameras are hidden to 'trap'



motorists.

The use of dummy flash units should receive favourable consideration as experience has shown they have a deterrent effect and are an excellent accident prevention factor. However, the same criteria for location (i.e. designated hot-spot areas) as for "live" cameras should be used. This restriction has been introduced by virtue of the arrangements made by the Secretary of State under Section 38, Vehicles (Crime) Act 2001.

Experience has further shown that one camera circulating between up to a maximum of ten sites and moved at regular intervals will produce an effective casualty reduction result.

Type approved unattended/automatic devices will have a second independent method of checking the primary speed measurement. One such method offered by manufacturers is the taking of two photographs of the offending vehicle at a known time apart which can be compared with the distance travelled within that time interval to arrive at the speed of the vehicle. Only approved methods of secondary checks should be utilised.

A survey of each site by the manufacturer or agent where an unattended automatic device is to be located must be carried out to ensure its suitability with regard to the manufacturer's instructions.

Before enforcement activity commences each installation will be the subject of a commissioning procedure at which the police will be present. The record of that commissioning will be retained for evidential purposes in case the integrity of the site is questioned.

Any alteration in the configuration of the site will require the site to be recommissioned. Great care should be taken when secondary check marks are replaced to engineering standards after resurfacing work.

At the time of the commissioning and/or subsequent recommissioning, it is recommended, a series of photographs showing the complete 360° area around the camera housing is taken and retained with the commissioning certificate.

15.5 Crime Prevention

All unattended enforcement devices represent a substantial monetary investment and the existence of this technology is not appreciated by all road users. The purchase and installation of equipment should be undertaken with this in mind. Manufacturers should be asked about the quality of poles, cabinets and locks, etc., and ideally devices should not be situated in positions at the roadside or locations that make it easy for them to be attacked. It is appreciated there may be an additional cost incurred in this but experience has shown an unwillingness by insurers to indemnify against



Code of practice for operational use of enforcement equipment

loss where there is a proven high risk of damage or theft.

Only alarms approved by PSDB and included within type approval may be used.

15.6 Trailer Mounted Unattended/Automatic Devices

Trailer mounted Gatso speed cameras are approved for use under strict operating and site set up guidelines published by the manufacturer or supplier of the equipment and agreed with PSDB.

All police personnel delivering instruction on the use of equipment should receive formal certified training in the site selection, commissioning of the site and operation of the equipment, and receive a personal copy of the operating instructions for the equipment.

The equipment supplier or manufacturer should survey all potential enforcement sites in advance, with representatives from both the police and local authority or contractors present as appropriate. A site survey report should be issued and retained by the police for future evidential purposes.

The site, once surveyed and found to be suitable, should be marked with secondary check lines to engineering standards and to the agreed national standard.

The site should be treated as a fixed site in relation to signing, and current signing policy should be adopted. Each individual installation requires re-commissioning of the site.

A firm level base should be either found or installed for the siting of the trailer, substantial enough to take the weight of the trailer without any subsidence.

The trailer should be placed in position and made stable and thereafter commissioned by **a trained person only**. This should take place every time the trailer is sited and a commissioning certificate completed.

The first time the trailer is sited at a location, a set of all round photographs should be taken and retained by the police unit operating that site. At subsequent use of the trailer at the same site, the photographs should be referred to, and if any changes have occurred at or around the site, a further set of photographs should be taken.

The person siting the trailer should ensure the position of the trailer is clearly marked and difficult to move and include that in evidence. When the trailer is subsequently serviced ideally the same person should visit the site and again include in evidence the fact that the trailer had not been moved since the last visit. **If it has been moved no prosecutions should take place from**



that film.

The security and safety of the trailer must be considered particularly if it is to be sited on a road or in a lay-by, as it would be intolerable for the trailer to be responsible for an accident during the hours of darkness because it had insufficient illumination.

Secondary check marks put in place for trailer mounted cameras cannot, under any circumstances, be used as secondary check marks for camera attached speedmeters which would normally be used in the attended actively operated mode.

15.7 Handling of Film and Video Tape

Any handling of film or videotape, including loading and unloading, must take place in accordance with any instructions laid down by the manufacturers.

The original untouched negative or videotape is the best evidence for the prosecution. The ability of the prosecution to prove continuity in loading, unloading and handling film until it is developed is vital.

Legally a notice of intended prosecution must be served within 14 days of the offence on either the driver or registered keeper. It is therefore important operational sites are visited regularly to recover exposed film, identify the registered keeper and serve a notice of intended prosecution within the 14 day period.

For attended devices, films or tapes may contain details of offenders from different sites on the same film due to the device being moved from site to site.

Operators should ensure the correct details of sites have been recorded both on a manual and on the datablock within the photographs.

If a device used in an attended mode failing to record either time/date/speed, etc., on the data block of the photograph, then unless the operator has recorded those missing details manually the check will have to be disregarded. This problem will not be evident until film has been developed.

In the event of an occurrence as above involving an unattended automatic device, then it will be of no evidential value and will be disregarded.

15.8 Film Processing

It is recommended the developing of the films be undertaken by a police photographic unit (either force or nationally based) or a confidential service offered nationally.



Code of practice for operational use of enforcement equipment

Some police photographic units may not have the necessary equipment to process films of the lengths produced by these devices. If this is the case, it is recommended lengths be reduced to workable size by cutting at 45° diagonally through a frame, (this practice will ensure there cannot be accusations of tampering with the film during the developing process.)

There will be no need for forces to make prints at this early stage as viewing for prosecution purposes will utilise the negatives.



16. Safety Camera Enforcement, Office Procedures

ACPO Road Policing Enforcement Technology recognises all police forces will determine their own operating procedures for the effective management of the Camera Enforcement or Back Office. This section of the Code of Practice does not attempt to guide forces or casualty reduction partnerships on the purchase of proprietary equipment and software available to facilitate this work. There are however elements of universal good practice which form part of the guidance offered in this section.

All staff that view films or images for evidential purposes must be suitably trained. Operators must have their Chief Officer's authority to carry out this task with prosecution decisions being made in accord with legislation, national and force guidelines.

Whatever wet film viewing device is used, it should be able to deal with a large reel of negatives, possess a zoom facility and be capable of reversing the film polarity (on occasions some vehicle registration marks are clearer in the negative mode).

Where the zoom facility and/or adjusting the contrast/brightness, or reversing the films polarity cannot identify a vehicle registration mark, the reading will be disregarded. PNC will not be used to establish identity by a search of a range of numbers/letters and clarifying by make/colour.

Visual identification of the offender's vehicle should be verified by confirming make and colour against the records maintained by DVLA or PNC. Best practice is for this to be made while the operator can see the image and the PNC or DVLA data extract. This reduces the chances of keying errors resulting in Notices of Intended Prosecutions being sent to incorrectly identified registered keepers.

A close examination should be made of the film by the operator with a view to ensuring it gives:

- Clear and unambiguous evidence of the offence.
- A record of all the information required by type approval.

Where there is a suggestion in the image that two or more vehicles are, or may, be in the measurement field, the reading must be disregarded.

The Road Traffic Act 1991, in amending the Road Traffic Act 1988 and The Road Traffic Offenders Act 1988, requires that before a conditional offer of fixed penalty can be made the circumstances of the offence must be considered by a police constable as suitable for such an offer to be made. Any audit trail must be robust enough to withstand any challenge this has not occurred.



16.1 The Secondary Check

When viewing any film, or any other means of image recording, exposed or collected in an automatic device, the images in respect of offences will be scrutinized using the approved secondary check procedure to verify the continuing accuracy of the device.

The secondary check method adopted will be in accordance with the Home Office Type Approval and manufacturers instructions.

16.2 The Use of Front Photography in Road Policing Enforcement

Since 1991 the expansion in the use of unattended and attended devices which record the circumstances of offences of excess speed or red light running on a photograph, video or digital image has been one of the key factors in the role of using enforcement to reduce death and injury on the roads.

The use of such devices was the subject of extensive discussion during the passage of the Road Traffic Act 1991 and much debate centred around the perceived intrusiveness of this type of equipment into the privacy of the occupants of a vehicle when an image of that vehicle was recorded. At the time of those discussions, rear photography of offending vehicles was the best technical option, and the fact that drivers would not be identified from such photographs possibly allayed any public disquiet and gave acceptance to the procedure of identification of offenders by enquiry through the registered vehicle keeper record.

A number of police forces in England and Wales have used unattended devices for several years and each has identified problems with the current process of identifying offenders. Apart from problems relating to the identification of vehicle class when large goods vehicles are recorded from the rear, or when number plates are partially or completely obliterated by loads carried on private cars, there are problems which relate to the use of unregistered vehicles or those vehicles where transfers of registered keepers have not been notified.

One of the areas of concern centres around the actual identification of the offender once the presence of a vehicle at the locus is agreed by the registered keeper. It is not uncommon to receive replies from registered keepers indicating that one or more persons could have been driving the vehicle on the day concerned and asking the police to be more specific as to the age and sex of the driver. They, the keeper, may then be able to identify the driver to the police.

The use of front photography, or simultaneous front and rear photography, can reduce the difficulties in driver identification but it is recognised that



some people may see its application as an intrusion into privacy and official surveillance of everyday living. For that reason the following protocol drafted in 1996 by the ACPO (RP) Traffic Enforcement Technology Sub-Committee. Any force which uses or, considers the use, of front or simultaneous photography must adhere to its principles.

The use of any image, recorded by a type approved enforcement camera, will primarily be for the prosecution of the offence of excess speed or red light running which it records. It must be recognised that sometimes images will record the presence of persons in a motor vehicle, which will be prima facie evidence of their involvement in connection with another criminal offence. Also, in addition to traffic related offences, the image may record the occupants of a vehicle thereby providing evidence in relation to another offence. It would not be right to have such potential evidence available and not use it in the investigation of these offences.

The use of the protocol will make it clear to the public at large that technological assistance and image recording is a fundamental part of the enforcement of traffic legislation in an effort to reduce death and injury on the roads and is not a complex surveillance system provided to allow official intrusion into the private life of individuals. The use of these images is proportionate and used correctly will assist in the identification of the offender without unnecessarily intruding on the privacy of innocent people.

16.3 The Protocol

The identification of any offender, whose alleged offence has been image recorded by a Type Approved enforcement camera, will normally be accomplished by application to the registered keeper of the vehicle to nominate the driver of the vehicle under Section 172 of the Road Traffic Act 1988.

An open approach to these enquiries will militate against mistaken or maliciously misleading responses, which would otherwise lead to more serious investigation relating to perverting the course of justice.

When front photography has been used: -

- (a) The registered keeper will be told at the time of the initial enquiry that the offence has been photographed (as at present) and that the record contains detail that may assist with the identification of the driver.
- (b) A copy of the photograph may be sent at this stage but the image should not be detailed enough to allow identification of the vehicle occupants.
- (c) Should the registered keeper nominate another person, then that person will also be advised at the time of first contact, that the image contains detail that may confirm the identity of the driver.



Code of practice for operational use of enforcement equipment

(d) Where it appears that an image or series of images may contain prima facie evidence relating to any other serious offence then the examination of those images is sanctioned for that specific purpose. The subsequent use of any image as evidence or part of an identification process is governed by the Police and Criminal Evidence Act 1984, the Criminal Investigation and Procedures Act 1995 and the Regulation of Investigatory Procedures Act 2000.

(e) Any potential defendant, in respect of a speed or red light offence, should be given the opportunity of viewing the image.

(f) The displayed image will only show that part of the vehicle, which permits the identification of the driver with the remainder of the passenger compartment obscured.

(g) The initial image, recorded by the device at the time of the alleged offence, will always remain in its total and unaltered condition as the 'best evidence' for subsequent production in Court if necessary.

16.4 Guidance for Decision Makers on 'Emergency Vehicles' Detected by Automatic or Attended Enforcement Cameras.

This protocol has been drafted at the request of decision makers in camera processing units nationwide who are confronted with photographic evidence of emergency vehicles exceeding the speed limit or failing to comply with a red traffic light.

The police service is unique in that it seeks to avail itself of this exemption and is also obliged to arbitrate on apparent offences by other emergency services. We must be seen to apply equitable standards for the safety and reassurance of the public.

Provision exists in law to protect drivers of emergency vehicles from prosecution for excess speed or red traffic light offences dependent upon the use to which the vehicle is being put at the time. There is no blanket exemption for these offences and each and every recorded event must be capable of justification to preserve the integrity of the operators and the police service.

Section 87 Road Traffic Regulation Act 1984 provides:

No statutory provision imposing a speed limit on motor vehicles shall apply to any occasion when it is being used for fire brigade, ambulance or police purposes, if the observance of that provision would be likely to hinder the use of the vehicle for the purpose for which it is being used on that occasion.



Code of practice for operational use of enforcement equipment

Various decided cases help to qualify the position.

A police car driven by a police-driving instructor on an exercise is being used for 'police purposes.' R v Abraham (1980) RTR 471.

We are reminded by Gaynor v Allen (1959) 2 QB 403; (1959) 2 all ER 664 that this section in no way qualifies a police drivers civil liability for negligence.

It is clear therefore that each case must be assessed on its merit. A duty of care is placed upon the drivers of these vehicles as displayed in Gaynor v Allen and by the rider in regulation 33(1)(b) of the traffic signs regulations and general directions 1994.

This regulation states that:

....when a vehicle is being used for fire brigade, ambulance or police purposes and the observance of the prohibition conveyed by the red signalwould be likely to hinder the use of that vehicle for the purpose for which it is being used then the restriction shall not apply to the vehicle, and the red signal shall convey the prohibition that the vehicle shall not proceed beyond the stop line in a manner or at a time likely to endanger any person or to cause the driver of any vehicle proceeding in accordance with the indications of light signals operating in association with the signals displaying the red signal to change its speed or course in order to avoid an accident.

In effect to treat the signal as a mandatory give way sign.

16.5 Immediate or emergency response calls.

These types of calls by marked police units clearly displaying emergency equipment may be accepted on face value but the following considerations need to be made to ensure the provisions of the legislation are not being exceeded.

- the time of day
- traffic conditions
- speed recorded
- speed of the vehicle against the time lapse since a signal turned red
- weather conditions as evidenced by the photograph
- the use of emergency lighting equipment.

These considerations must be equally applied to covert units.



Code of practice for operational use of enforcement equipment

ACPO has invited Chief Constables to extend this provision to vehicles of kindred agencies. All forces are advised to have in place appropriate administrative procedures to show suitable checks have been made to validate any occurrence that indicates a prima facie offence by an emergency service vehicle where the exemption is being sought.

The force in whose area the offence was detected will take the decision as to whether the exemption applies.

It is for the driver of the emergency vehicle to satisfy the requirements of the exemption in all cases and for that application for an exemption to be ratified by an officer of the rank of Superintendent.

Only by the application of this guidance can the police service be seen to be discharging its obligations to properly investigate apparent breaches of the law and to provide adequate protection to staff administering the systems, and the drivers of vehicles diligently discharging their duty.

16.6 Storage of Information

Forces and highway authorities will wish to consider the logging of information produced by such devices for statistical and easy reference purposes. This may be manual and/or computer based. Where databases hold detail of individuals the Data Protection legislation applies and operators should refer to the ACPO Code of Practice for Data Protection.

A process to allow the inspection of decisions made to disregard checks due to missing details on a film should be maintained.

The evidence produced by these devices will have to be retained and stored for evidential purposes. This should be in accordance with individual force instructions following consultation with local CPS and take into consideration:

- Outstanding cases e.g. where defendants have failed to appear,
- Appeals
- Civil Proceedings

16.7 Prosecution Procedures and advice on Good Practice

Schedule 9 Paragraph 6(3) to the Criminal Justice and Public Order Act, 1994 amends Section 1 of The Road Traffic Offenders Act, 1988 to provide for the service of NIP's by first class post.

To ensure service can be proven, initial Service of Notice of Intended Prosecution and Section 172 Notices should be made by recorded delivery.



Code of practice for operational use of enforcement equipment

Where there is no response to the initial recorded delivery notice, a reminder notice/letter can be sent by first class mail between 7 and 28 days of the first notice.

Experience shows "reminder" letters usually prompt a high level of response; recorded delivery letters are sometimes seen as threatening and ignored.

Some forces have reported difficulty with the courts in identifying the locus of the offence for a failure to comply with a Section 172 notice. There is no definitive court view, although the majority view is the locus of the offence is the point of issue of the notice.

16.8 Cases adjourned Sine Die due to no date of birth

When all possible enquiries have been completed in respect of a Section 172 Notice and the matter has been to court, magistrates are adjourning cases heard in absentia because the date of birth of the offender is not known.

The possibility of including the date of birth on the registration document is being pursued by the DVLA. This does not solve the problem where another person is driving the vehicle.

In these circumstances it is considered best practice to place an entry on PNC as being of interest to the relevant force, which may provide the opportunity to trace the offender.

Forces will need to be in a position to show to the courts they have taken reasonable steps to identify the driver and /or the registered keeper of a vehicle if they are to achieve a successful prosecution.

A number of forces have expressed concern about the resource implications in follow up enquiries from non-response to notices or reminder letters. However, experience has shown where such enquiries are undertaken rigorously, they often yield benefits in detecting other criminal offences.

Some responses to a Section 172 notice will state there was more than one possible driver at the material time and the keeper is unable to specify the driver. In these circumstances and, where front or simultaneous front and rear photography is used, the images may be used to identify the driver **in accordance with the protocol.**



Appendices





Appendix A

Digital Radio and Traffic Enforcement Equipment

This table shows the shortest distance tested in each category where no interference was detected. Whilst devices may operate without interference at shorter distances, these distances should be regarded as the minimum safe operating distances.

Where N/T is shown the precautionary 10m separation must be used

Lasers and Laser-Based Devices	Tetra handset	GSM on belt	TETRA mobile	GSM mobile
LTI 20-20	0.05 m	0.05 m	0.5 m	0.5 m
LTI 20-20 Speedscope	0.1 m	0.05 m	0.5 m	0.5 m
Lastec Local	1.0 m	0.5 m	10.0 m	0.5 m
LaserCam	1.0 m	3.0 m	2.0 m	3.0 m
Kustom ProLaser II (with RFI detector disabled)	0.1 m	0.05 m	0.5 m	0.5 m
Kustom Prolaser II	5.0 m	0.2 m	10.0 m	0.5 m
Kustom ProLaser II with Laser Data Interface, Auto-vision and AV Camera	2.0 m	0.5 m	10.0 m	0.5 m
LTI 20.20 UltraLyte 100	0.05 m	0.05 m	0.5 m	0.5 m
Jenoptick Laser Patrol	0.05 m	0.05 m	0.5 m	0.5 m
Unipar Urban Speed Ace	0.2 m	0.5 m ⁽¹⁾	0.5m	0.5 m
Cleartone Stealth Speedlaser	0.05 m	0.05 m	0.5 m	0.5 m
Riegl LP90-235/P	0.05 m	0.05 m	0.5 m	0.5 m
Riegl FG21-P	0.05m	0.05 m	0.5 m	0.5 m
Leica XV2 Speed Laser	0.05m	0.05 m	0.5 m	0.5 m
Autovelox	N/T	N/T	N/T	N/T



Radars and Radar-Based Devices	Tetra handset	GSM on belt	TETRA mobile	GSM mobile
Gatso Mini Radar Mk3	2.0 m	0.1 m	10.0 m	1.0 m
Gatso Mini Radar Mk4	1.0 m	10.0 m	5.0 m	2.0 m
Kustom HR4	10.0 m	3.0 m	10.0 m	3.0 m
Kustom Roadrunner	10.0 m	0.5 m	10.0 m	0.5 m
Kustom Falcon	5.0 m	1.0 m	10.0 m	0.5 m
Kustom Falcon Cordless	0.5 m	2.0 m	3.0 m	0.5 m
Kustom HR8	2.0 m	10.0 m	10.0 m	10.0 m
Muniquip KGP	10.0 m	3.0 m	10.0 m	10.0 m
Speedar SR1	1.0 m	N/T	1.0 m	0.5 m
Gatso BV24 with AUS on Tripod	0.05 m	N/T	0.5m	0.5m
Gatso BV24 with AUS on Tripod + Weather proof cabinet	0.05 m	0.05 m	0.5 m	0.5 m
Gatso BV24 with AUS 240v fixed site or trailer mounted	0.5 m ⁽¹⁾	0.5 m ⁽¹⁾	1.0 m	0.5 m
Gatso BV24 with AUS 12v fixed site or trailer mounted	0.5 m ⁽¹⁾	0.5 m ⁽¹⁾	0.5 m	0.5 m
Serco SES type 1 (M25 Gantry)	N/T	N/T	N/T	N/T
Techscan CM1 450	N/T	N/T	N/T	N/T



Code of practice for operational use of enforcement equipment

Piezo and Pneumatic Speed Devices	Tetra handset	GSM on belt	TETRA mobile	GSM mobile
Speedmaster DS2 with pneumatic sensors	0.05 m	0.05 m	0.5 m	0.5 m
Speedmaster DS2 with pneumatic sensors + Autovision 2	5.0 m	2.0 m	10.0 m	0.5 m
Speedmaster DS2 with piezo sensors	0.05 m	0.05 m	0.5 m	0.5 m
Speedmaster DS2 with piezo sensors + Autovision 2	3.0 m	1.0 m	10.0 m	0.5 m
Speedmaster DS3 with piezo sensors	0.05 m	0.05 m	0.5 m	0.5 m
Speedmaster DS3 with piezo sensors + Autovision 3	2.0 m	2.0 m	10.0 m	0.5 m
Micro Mercury Speed 90500	0.1 m	0.05m	0.5m	0.5m
Micro Mercury Vision System 92600	N/T	N/T	N/T	N/T
Traffiphot S Piezo	0.5m ⁽¹⁾	0.5m ⁽¹⁾	0.5m	0.5m
Truvelo Combi S Piezo Camera	0.05 m	0.05 m	0.5 m	0.5 m
Truvelo Combi S (mem card) Piezo Camera	0.2m	0.05m	0.5m	0.5m
Truvelo M4 Squared SMD	0.05m	0.05m	0.5m	0.5m
Speed man Enforcement	0.05 m	0.05 m	0.5 m	0.5 m



Distance / Time Devices	Tetra handset	GSM on belt	TETRA mobile	GSM mobile
SVDD	N/T	N/T	N/T	N/T
TSS VASCAR 4000 – If all TETRA in vehicle, hand set and mobiles, are off	2.0 m	2.0 m	2.0 m	2.0 m
TSS VASCAR 5000 – stand alone out of the vehicle	0.05 m	0.05 m	0.5 m	0.5 m
TSS VASCAR 5000 - If all TETRA in vehicle, hand set and mobiles, are off	2.0 m	2.0 m	2.0 m	2.0 m
SPDM 1- stand alone out of the vehicle	0.05 m	0.05 m	0.5 m	0.5 m
SPDM 2- stand alone out of the vehicle	0.05 m	0.05 m	0.5 m	0.5 m
Police Pilot 2600 + Provida 2000 Camera System – If all TETRA in vehicle are off	2.0 m	2.0 m	3.0 m	2.0 m



Code of practice for operational use of enforcement equipment

Traffic Signal Cameras	Tetra handset	GSM on belt	TETRA mobile	GSM mobile
Gatso BV 36	0.5 m ⁽¹⁾	0.5 m ⁽¹⁾	0.5 m	0.5 m
Traffiphot 111G	0.5 m ⁽¹⁾	0.5 m ⁽¹⁾	0.5 m	0.5 m

Note

(1) not tested below 0.5 m

Where N/T precautionary 10m applies





Appendix B

Speedmeters Type Approved by the Secretary of State for Police Use

Radar Speed Measuring Devices		
Kustom Falcon	Approved from 31 July 1986	Traffic Safety Systems Ltd Ashton House, Granville St Aylesbury, Bucks HP20 2JR 01296 397000
The Gatso Mini Radar MK3	Approved 1986	Greenwood Electronics F10A Festival Business Centre 150 Brand Street Glasgow G51 1DH
The Gatso Mini Radar Mark 4	Approved 1986	Greenwood Electronics
Kustom HR 4	Approved from 1 January 1987	Traffic Safety Systems Ltd
Kustom HR8	Approved from 1 January 1987	Traffic Safety Systems Ltd
Kustom Roadrunner	Approved from 1 January 1987	Traffic Safety Systems Ltd
Muniquip K-GP	Approved from 8 November 1989	Unipar Services The Old Stables, 65, Lower Green Road, Tunbridge Wells, Kent. TN4 8TW. 01892 549606
Kustom Cordless Falcon	Approved from 31 October 1997	Traffic Safety Systems Ltd
Speedar SR1	Approved from 10 February 1998	Ottery Electronics, The Drive, Ifold Loxwood W Sussex RH14
Gatsometer BV Type 24 +AUS speed camera	Approved from 1 July 1992	SERCO Technology Jackson Way

Code of practice for operational use of enforcement equipment



(commonly known as the "Gatso Camera")		Great Western Industrial Park Southall Middx. UB2 4SF. 0208 867 4400
--	--	--

The Serco Speed Enforcement System Type 1 with either the Techspan Systems Controlled Motorway Indicator Type 450EE or the Sécurité et Signalisation (SES) Controlled Motorway Indicator Type 450EE [M25 controlled motorway project]	Approved from 24 May 1995	SERCO Technology Jackson Way Great Western Industrial Park Southall Middx. UB2 4SF. 0208 867 4400
---	---------------------------	---

Light beam Speed Measuring Devices (laser)		
The LTI 20.20. TS/M	Approved from 1 November 1993	Tele-Traffic (UK) Ltd C2 Harris Road, Wedgnock Industrial Estate, Warwick CV 34 5JU. 01926 407272
The Kustom ProLaser II	Approved from 18 May 1995	Traffic Safety Systems Ltd
The LTI 20.20 Laser Hand Held		Tele-Traffic (UK) Ltd
The LTI 20.20. TS/M "Speedscope"	Approved from 1 April 1996	Tele-Traffic (UK) Ltd
Riegl LR90-235/P	Approved from 16 October 1998	RIEGL GmbH A-3580 Horn, Wiener Strasse 2, Austria
Clearstone Stealth Speedlaser	Approved from 5 May 1999	Clearstone Telecoms plc Pontyfelin Industrial Estate, New Inn, Pontypool, South Wales. NP4 0DQ.



Code of practice for operational use of enforcement equipment

		01495 752323.
Laser Data Interface (LDI) Only when used in conjunction with both Kustom ProLaserII Speed Measuring Device and Autovision (AV3)	Approved from 24 May1999	Traffic Safety Systems Ltd
Unipar Urban Speed Ace	Approved from 28 May 1999	Unipar Services
LTI 20.20 UltraLyte 100	Approved from 15 July 1999	Tele Traffic U.K.
Jenoptik LaserPatrol	Approved from 15 October 1999	Truvelo (UK) LTD 7, Teddington Business Park, Teddington TW11 9BQ. 0208 977 1228
Riegl FG21-P	Approved from 23 November 1999	Riegl GmbH
Leica XV2 SpeedLaser	Approved from 12 February 2001	Genesis UK Ltd 4 Mendip Vale Cheddar Business Park Wedmore Road Cheddar BS27 3EL
Autovelox 104/C-2		Sodi Scientifica Via Poliziano 50040 Settimelo di Calenzano, Florence, Italy
Prolaser III	Approved from 21 October 2002	Traffic Safety Systems Ltd



Image Capture Systems For Use Only With Type Approved Laser Speedmeters

LASTEC Local Video System [for use with LTI 20.20 TS/M or LTI 20.20 TS/M "Speedscope" only]	Approved from 10 February 1998	TeleTraffic (UK) Ltd
LaserCam Digital Camera System [for use with LTI 20.20 TS/M or LTI 20.20 TS/M "Speedscope" only]	Approved from 26/2/98	Locktronic Systems Pty Ltd, 29-31 Heatherdale Road Ringwood, Victoria, Australia Tel: (03)9872 5577 Fax: (03)9872 5727
Autovision 3 (AV3) when used in conjunction with the Prolaser III Hand Held Speedmeter	Approved from 17 February 2003	Traffic Safety Systems Ltd

Road Sensors Speed Measuring Devices (activated by means of sensors or cables on or near the surface of the road)

Micro Mercury 90500	Approved from 9 August 1993	BDL Systems Ltd, 14, Denmark Lane, Poole Dorset. BH15 2DG 01296 397000
Micro Mercury Vision System 92600	Approved from 9 August 1993	BDL Systems Ltd
The SpeedMaster DS2		Traffic Safety Systems Ltd
The Autovision 2		Traffic Safety Systems Ltd
The Speedman Enforcement System		Golden River Traffic Ltd, Churchill Road, Bicester, Oxon OX6 7XT Tel 01869 24040



Code of practice for operational use of enforcement equipment

The Truvelo M4 Squared speed measuring device		Truvelo (UK) LTD 7, Teddington Business Park, Teddington TW11 9BQ. Tel: 0208 977 1228
The Traffiphot "S" Speed detection device	Approved from 11 March 1994	Peek Traffic Ltd, Kings Worthy, Winchester, Hants. SO23 7QA. 01962 883200
The Truvelo Combi S	Approved from 23 June 1997	Truvelo (UK) Ltd
The Truvelo Combi S-mc Speed Camera System	Approved from 15 April 1999	Truvelo (UK) Ltd
Speed Master DS3 and Autovision 3 (AV3) Approved from same date and subject to the condition that it be used in conjunction with Speedmaster DS3.	Approved from 24 May 1999	Traffic Safety Systems Ltd

Distance Over Time Measuring Devices

Speed Violation Detection Deterrent	Approved from 1 April 1999	Speed Check Services, Deterrent (SVDD) Buchanan House, 24-30 Holborn, London EC1N 2LX Tel: 0207 870 9357
-------------------------------------	----------------------------	---

Interface for Railway Signals

Peek Railway Interface (to be used with Traffiphot IIIG RedLight Monitor)	Approved 17 July 1999	Peek Traffic
B.I.C Railway Interface		SERCO



Red-light Cameras

Gatsometer BV Type 36	Approved from 1 January 1993	SERCO Technology
The Traffiphot IIIG	Approved from 11 March 1994	Peek Traffic Ltd

Bus Lane Enforcement Cameras

JAI BUS-ter bus mounted camera	Approved from 5 December 1997	JAIVISION Ltd UK Audley House, Northbridge Road, Berkhampstead, Herts HP4 1EH 01442 879 669
Peek Guardian Freelane Roadside Camera	Approved from 7 September 1998	Peek Traffic

Unlicensed Vehicle Detector

Stingray UVD	Approved from 4 June 2001	Futronics Ltd Purley Way, Croydon, Surrey CR0 0XY
--------------	---------------------------	---